



CATÁLOGO GENERAL

07/13





Somos una empresa joven y dinámica, con la particularidad que a nuestro equipo nos avalan decenas de años de experiencia a nivel internacional en el sector de los componentes para maquinaria agrícola e industrial.

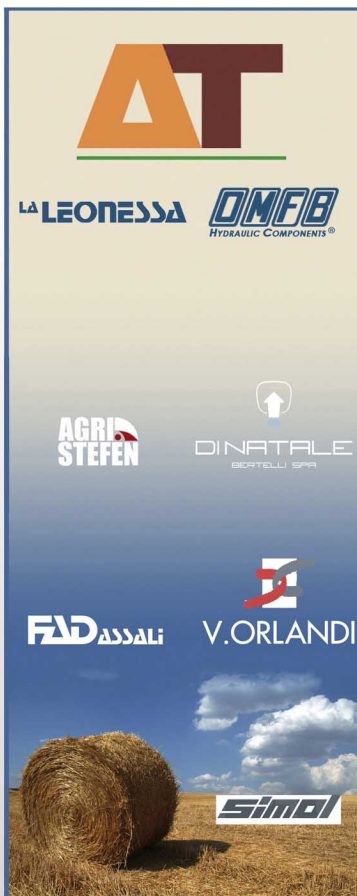

Distribuimos grandes marcas destacadas por su compromiso con la calidad y los productos bien hechos. Cilindros telescópicos Di NATALE BERTELLI, ejes FAD y AGRISTEFEN, coronas y rodetes LA LEONESSA, bombas y centrales OMFB, enganches ORLANDI, apoyos SIMOL,... Todos nuestros productos están fabricados para cumplir con los usos y prestaciones más exigentes.

Nuestro trabajo está orientado a fidelizar a nuestros clientes, para ello estamos comprometidos con ofrecerles seguridad, calidad, servicio y buscar todas las soluciones que necesiten. Invertimos todos nuestros recursos en disponer de una buena estructura, medios productivos y un amplio stock permanente para dar el mejor y más esmerado servicio.

Les presentamos a continuación el nuevo catálogo general en el que hemos intentado ofrecer una visión lo más amplia posible de la gama de productos que disponemos, así como información técnica, de uso y montaje. Este catálogo está también a su disposición permanentemente actualizado en nuestra página web: www.artitrail.com

Con el deseo de poder contar con su confianza en el futuro y con nuestro compromiso de dedicar todo nuestro esfuerzo para convertirnos en sus permanentes colaboradores, quedamos a su entera disposición.



Índice

1 CILINDROS TELESCÓPICOS	3
Presentación Di Natale Bertelli	4
Información técnica	7
Cilindros telescopicos tipo "F" (agujero pasador)	11
Cilindros telescopicos tipo "R" (rótula)	13
Cilindros telescopicos giro, agujero base y doble rótula	14
Accesorios para cilindros	15
2 RODETES, CORONAS Y GRUPOS SIN FÍN	18
Presentación La Leonessa	19
Rodetes La Leonessa	21
Coronas de dirección industrial	23
Coronas de orientación La Leonessa	25
Anillos laminados sin costuras	25
Grupos sinfín	27
3 EJES Y SUSPENSIONES	29
Presentación FAD Assali / Agristefen	30
Semiejes y ejes sin freno	32
Semiejes pivotantes y cabezas de trailla	33
Ejes con freno "monoblock"	34
Ejes con freno tambor fundido	35
Ejes auto direccionales y comandados	36
Gama ejes Agristefen	37
Accesorios ejes	39
Suspensiones Mecánicas con o sin tirantes	41
Suspensiones bogies	43
Suspensiones hidráulicas y neumáticas	45
Recambios y despieces	47
4 CONJUNTOS DE RUEDAS CON NEUMÁTICOS	49
Remolques turismo y varios	50
Agroindustrial, remolques, cisternas y usos varios	51
Agrícola de flotación y tracción	52
Industrial y superelásticos (macizos)	53
Obra pública y movimiento de tierra	54
Jardín, motocultores y pequeños tractores	56
Índices de carga y velocidad de los neumáticos	58
5 ACCESORIOS Y COMPONENTES VARIOS	59
Bombas, centrales hidráulicas y grupo motor/bomba OMFB	60
Apoyos mecánicos, hidráulicos y ruedas jockey SIMOL	64
Ballestas y sus accesorios	70
Enganches, puntas de lanza y 5ª rueda ORLANDI	72
Cadena esparcidores	77



CILINDROS TELESCÓPICOS

Di Natale Bertelli fábrica desde 1960 cilindros hidráulicos telescópicos para basculación agrícola e industrial con una producción anual de más de 65.000 unidades, siendo proveedor estratégico y de máxima fiabilidad en todos los mercados mundiales. Nuestros cilindros se fabrican con las siguientes características:

- Todas las materias primas (tubos, redondos macizos laminados,...) son de fabricación europea, certificadas para garantizar la máxima seguridad productiva, los certificados son archivados 5 años.
- Todos los componentes y los accesorios son proyectados con un coeficiente de seguridad $K_s=1,5$ en línea con las normas europeas de seguridad.
- Todos los trabajos son verificados mediante programas de control aprobados por la aseguración de la calidad, que prevé un control fase a fase sobre todo el proceso productivo.
- Todas las piezas son medidas con apropiados instrumentos periódicamente controlados y verificados en la sala de metrología en nuestras instalaciones.

Primera empresa europea de cilindros telescópicos en obtener la certificación UNI EN ISO 9001 02/1997

En el 2001 se obtuvo UNI EN ISO 9001-2000

En el 2010 se obtuvo UNI EN ISO 9001-2008



Todos los cilindros telescópicos DNB llevarán tarjeta identificativa y de homologación CE con referencia a la nueva normativa en vigor CE 2006/42.



PRUEBA:



Todos nuestros cilindros se prueban hasta fin de carrera a 240 bar lo que garantiza al 100 % nuestros artículos. Durante la prueba se lubrica internamente todos los componentes y en particular las guarniciones, evitando que estas se puedan dañar con el tiempo.



Tratamiento TF1 TENIFER:

DNB implantó este tratamiento en los años 70 y ha conseguido una notable experiencia en este proceso que se realiza de forma totalmente automática en nuestras instalaciones, con controles diarios del material tratado para garantizar la máxima calidad.

Las expansiones presentan un óptimo espesor anti fricción y un correcto brillo. Permite un perfecto deslizamiento de las expansiones y una mayor resistencia al uso y la fatiga.

Tratamiento principalmente utilizado en la industria automovilista y aeronautica para las piezas que superan los 900 millones de ciclos.

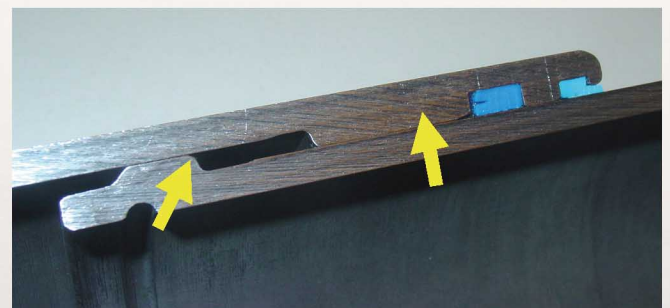

GUIAS

Las guías superiores se obtienen por la mecanización de un tubo laminado sin soldadura de gran espesor MW450 y E470HL de altísima resistencia mecánica adquirido a los dos productores europeos Mannesmann® y Tenaris-Dalmine®, lo que permite que la guía sea parte de la misma expansión. Las guías en acero están templadas, por lo que no sufre desgaste por el uso. Esta característica diferencia la calidad de nuestro producto con respecto a otros productores que usan la guía de plástico para el mismo cometido. Este procedimiento ofrece una ulterior garantía de seguridad permitiendo la máxima extensión del cilindro hasta fin de carrera.

EXPANSIONES

Las expansiones se obtienen partiendo del mismo tubo de gran espesor, por lo que los toques de las expansiones se consiguen mediante torneado, lo que garantiza la resistencia mecánica a esfuerzos axiales y radiales, y permite que el cilindro trabaje hasta fin de carrera .

SUPERFICIE LAPEADA

Las expansiones son expuestas a una fase posterior de lapeado superficial con la que se obtiene una rugosidad máxima: 0,2 micras con la consiguiente mayor durabilidad de las guarniciones que trabajan sobre una superficie más lisa.

RASCADORES Y GUARNICIONES

Están contruidos con poliuretano puro marca DuPont y tienen un doble labio de estanqueidad contra el agua, el polvo y contención de aceite.

T° entre -40° a +110° C, Velocidad 0,5 m/s , Presión 400 Bars, Rugosidad máx. adm. 0,50 micras

El proveedor es la empresa Guarnitec con más de 50 años de experiencia, propietaria también de la marca Tecnolan, Tecnoleo y Italseals, cada guarnición está marcada con nuestro logo para garantizar autenticidad.

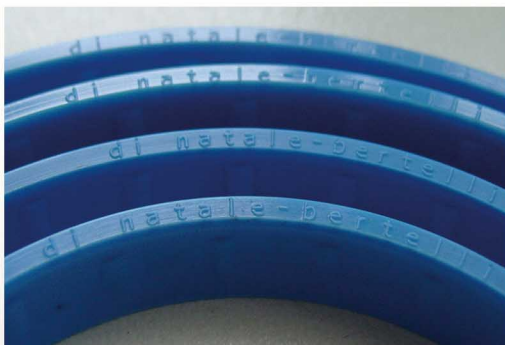

CUBETA DE BLOQUEO

Es de forja, material más resistente a las exigencias mecánicas respecto a la cubeta torneada de redondo: Acero forjado S355J2G3 UNI 10025 Rm=510 N/mm². La forma aporta mayores espesores allí donde lo necesita, la final del cuerpo externo. La arandela O-ring trabaja sobre el fondo por lo que no debilita la estructura de la cubeta.



ASISTENCIA Y GARANTIA:

Gracias a nuestro programa informático, verificamos el tipo de cilindro más idóneo. La documentación obtenida podrá ser utilizada para la homologación y el manual CE, conjuntamente con la Declaración del Fabricante. La garantía Di Natale - Bertelli, S.p.A. tiene una duración de 18 meses, que cubre los accesorios y componentes de recambio y está incluida la inmediata sustitución del artículo.

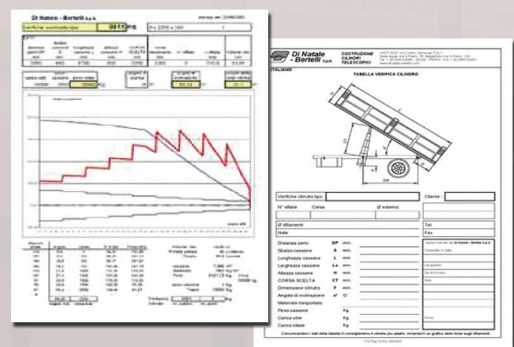

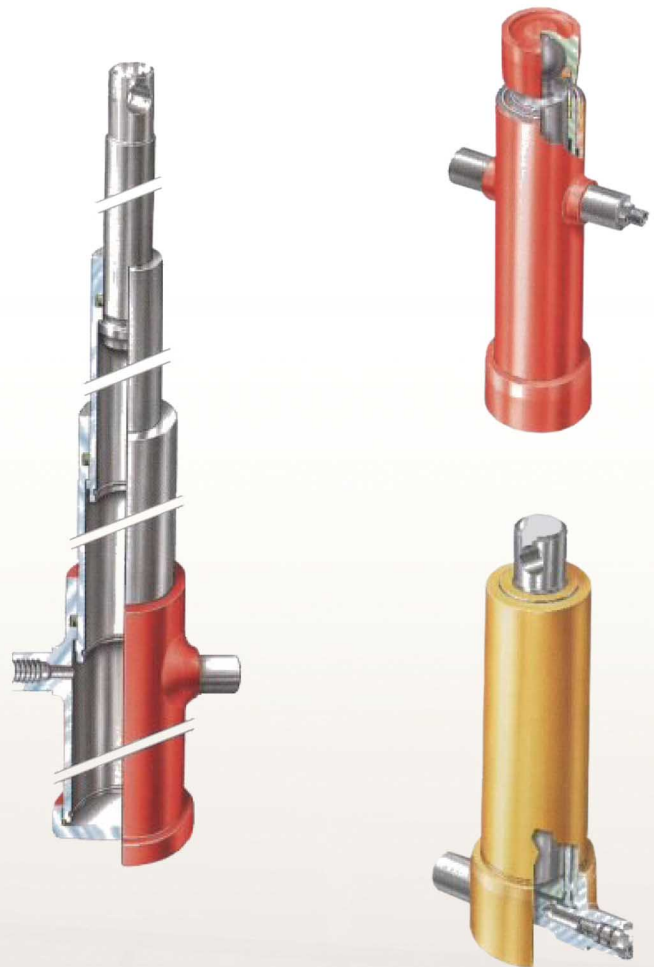
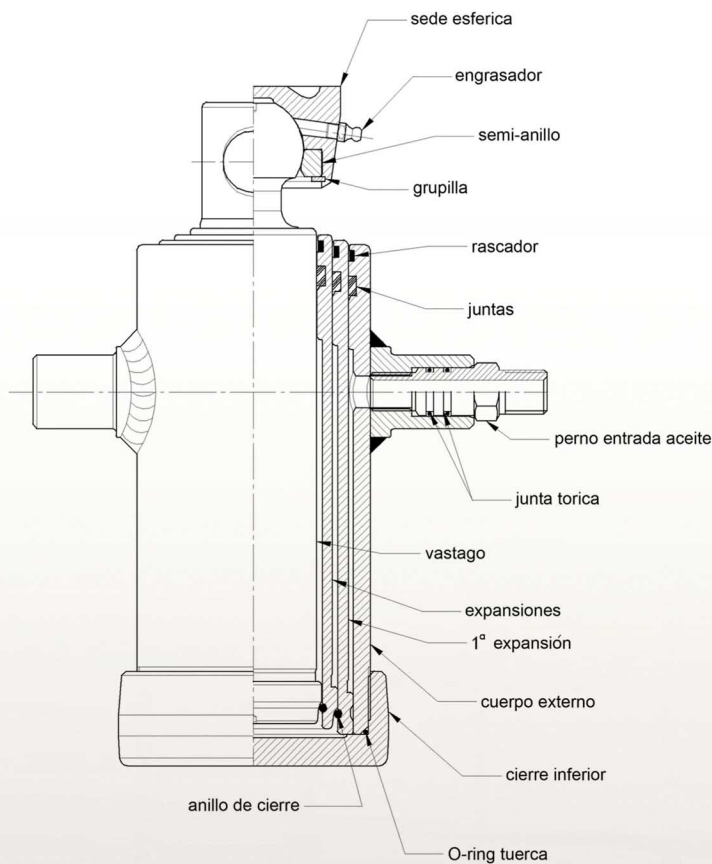

CARACTERÍSTICAS TÉCNICAS

Material

Los cilindros telescópicos son construidos con tubo laminado sin soldadura gran espesor: ST.52.0 DIN - 1629 R=500-650 N/mm² Rs=335 N/mm² MW 450 20 Mn V 6 R=550-720 Nmm² Rs=420 N/mm² Base y sedes esféricas de acero estampado: Fe 510 R=450-630 N/mm².

Expansiones

El tratamiento de nitruración salina propiamente denominado "proceso TENIFER TF1 Degussa" adoptado por Di Natale - Bertelli S.p.A. permite a las expansiones trabajar acero sobre acero, por lo tanto están libres de anillos de guía, pudiendo contar con superficies de deslizamiento fuertemente resistentes al desgaste y al agarrotamiento, consiguiendo además una dureza superficial elevado par a HV-5/12 = 500-550.

Las expansiones, gracias a lo anteriormente expuesto, quedan libres de guías de bronce y anillos y esto les permite una resistencia mecánica en los extremos notablemente más elevada que los estándares del mercado y quedan exentos de los problemas de rebabas.

Esto además permite una guía mayor en largura y la posibilidad de hacer trabajar al cilindro a final de carrera a la máxima presión.

Superficies

Las superficies externas de las expansiones se someten a una primera fase de rectificación y posteriormente a un lapeado, consiguiendo un grado de rugosidad igual a: Ra <= 0,15 controlado a cada ciclo a través de rugosímetro.

También en esta fase del ciclo productivo cada trozo es sometido a control a través de rugosímetro

Juntas

Las juntas y los rascadores son de configuración especial diseño de Di Natale-Bertelli, S.p.A.:

Material: Poliuretano puro, Du pont,
Presión máx. 400 Kg./cm², 395 Bares,

Temperatura: de -40 a 110 °C.

Velocidad: 0,5 m/s

Aceite: aceites hidráulicos y lubricantes a base mineral

Prueba

Todos los cilindros están sometidos a una prueba final con presión oleodinamica igual a 240 Kg/cm², 235 Bares. Los cilindros con diámetro 240 mm y otros, son probados a 205 Kg/cm², 200 Bares.

Normas

Todos los productos están diseñados según las normas internacionales estándares CNR-UNI 10011 utilizando un coeficiente de seguridad Ks = 1,5.

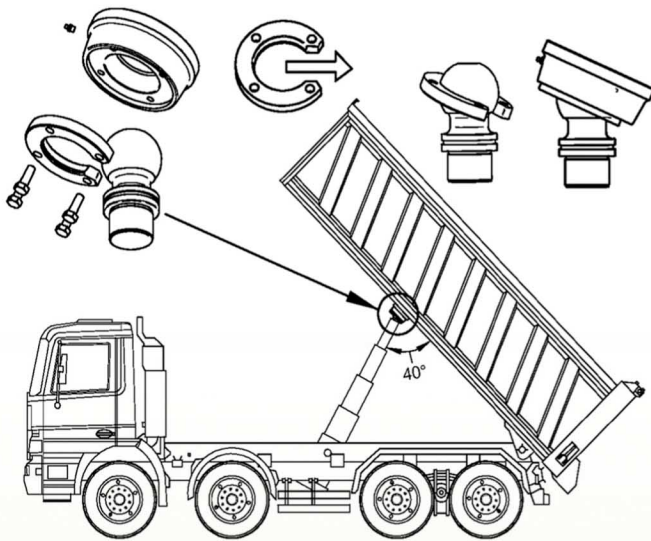

A fin de obtener una inclinación hasta 40° las rotulas Ø 73 y Ø 92 tiene que ser soldadas con la abertura del anillo hacia la parte posterior.

PRECAUCIONES A TENER EN CUENTA PARA UN CORRECTO MONTAJE

- Durante el montaje del cilindro, proteger las expansiones de gotas de soldadura, barnizado y de otros cuerpos extraños.
- Prestar la máxima atención durante la fase de barnizado protegiendo con cinta adhesiva u otro la parte superior de las expansiones, evitando que la pintura penetre dentro de las expansiones, dañando las juntas.
- Sobre el circuito oleodinámico aplicar una válvula de máxima presión, tarada a 200 Bares.
- Limpiar el interior del depósito y los latiguillos e incorporar filtros adecuados, y soplar el circuito antes del empleo
- En posición de reposo, la caja no tiene que apoyar nunca en el cilindro. Siempre dejar 20 mm como mínimo.
- Controlar que durante el funcionamiento el cilindro no sea obstaculizado por otros componentes de la caja y verificar el ángulo de la rotula.
- Evitar el lavado del cilindro con hidrolimpiadoras a alta presión.
- Usar aceites hidraulicos y lubricantes a base mineral con viscosidad de 2 a 6 Engler a 50°.
- Densidad aconsejada del aceite:
 - ISO 22 para temperatura de -18°C a +5°C
 - ISO 32 para temperatura de 0°C a +25°C
 - ISO 68 para temperatura de -10°C a +38°C

NORMAS DE SEGURIDAD DE RESPETAR

- No superar la presión max. de trabajo.
- Cargar dentro de los límites máximos de capacidad.
- Distribuir la carga de manera uniforme.
- Bascular siempre sobre terreno firme
- Bascular siempre con el vehículo parado.
- Bascular siempre en zonas libres de personas y obstáculos.
- En caso de subida irregular de la caja bajarlo inmediatamente y averiguar las posibles causas.
- No mover el vehículo para ayudar la descarga de materiales.
- Repartir la carga solamente con la caja en descanso.
- Controlar siempre la presión de los neumáticos

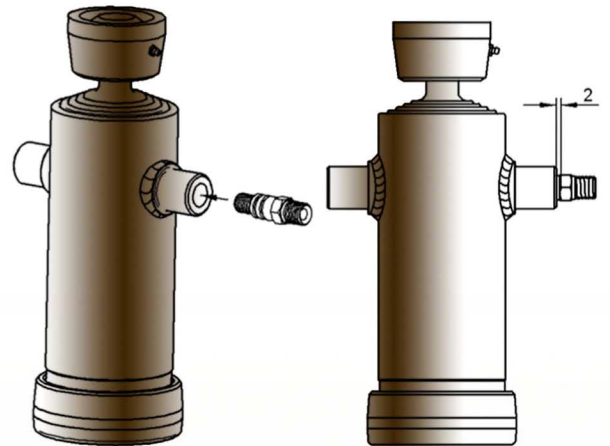

Introducir el perno en el cilindro, atornillar dejando 2 mm. De modo tal de permitir la regular rotación del perno durante la basculación.

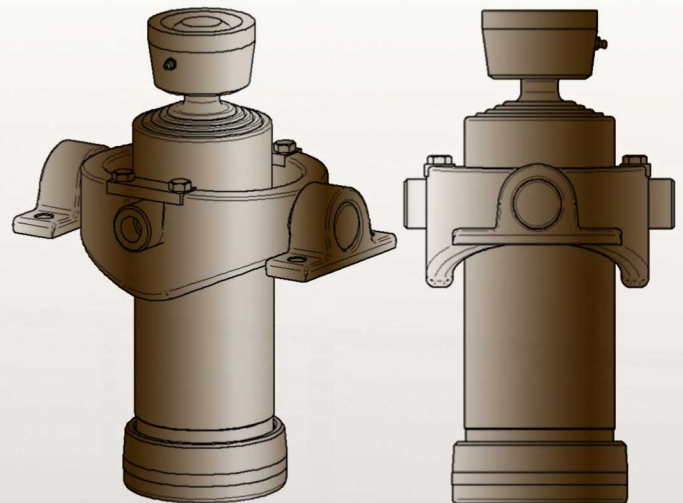

Para un correcto montaje se aconseja el uso del soporte oscilante y sus respectivos soportes.

- No trabajar nunca bajo la caja abatible, si no es en lugares equipados y respetando las normas de seguridad.
- No forzar la válvula de máxima presión o la regulación de los aparatos de final de carrera.
- Aconsejamos utilizar el racor con la válvula de retorno que permite el bloqueo de la caja abatible en caso de dañarse o rotura de el tubo de aceite
- Di Natale- Bertelli informa que sus productos no sean utilizados hasta que la maquinaria que tienen que formar parte no haya sido declarada conforme a la Directivas Máquinas 89/392 CE y sus sucesivas modificaciones y en consecuencia provistas de la marca CE.

ATENCIÓN

El incumplimiento de estas normas anula automáticamente la garantía del cilindro.

PRESIÓN MÁX. DE TRABAJO 200 - 220 BAR

TABLA DE CAPACIDAD DE ELEVACIÓN DE CADA EXPANSIÓN.

PRESIÓN Bars	EXPANSIONES													
	∅ 46	∅ 61	∅ 68	∅ 76	∅ 88	∅ 91	∅ 107	∅ 126	∅ 145	∅ 165	∅ 187	∅ 210	∅ 236	∅ 265
100	1,6	2,9	3,6	4,5	6	6,5	8,9	12,4	16,5	21,3	27,4	34,6	43,7	55,1
125	2	3,6	4,5	5,6	7,6	8,1	11,2	15,5	20,6	26,7	34,3	43,3	54,7	68,9
160	2,6	4,6	5,8	7,2	9,7	10,4	14,3	19,9	26,4	34,2	43,9	55,5	69,9	88,2
180	2,9	5,2	6,5	8,1	10,9	11,7	16,1	22,4	29,7	38,4	49,4	62,3	78,7	99,2
200	3,3	5,8	7,2	9,0	12,1	13,0	17,9	24,9	33,0	42,7	54,9	69,2	87,4	110
220	3,6	6,4	7,9	9,9	13,3	14,3	19,7	27,4	36,3	47,0	60,4	76,1	96,2	121

CAPACIDAD EN TONELADAS

TABLA DE LA CARRERA NECESARIA PARA INCLINAR LA CAJA AL VALOR DESEADO.

D.P. = Distancia entre el perno del cilindro y el perno de basculación en mm.

° = Inclinación de la caja.

C = Carrera del cilindro en mm.

DP = mm.	C = mm.				
	40°	45°	50°	55°	60°
800	547	612	676	739	800
900	616	689	761	831	900
1000	684	765	845	923	1000
1200	821	918	1014	1108	1200
1400	958	1072	1183	1293	1400
1600	1094	1225	1352	1478	1600
1800	1231	1378	1521	1662	1800
2000	1368	1531	1690	1847	2000
2200	1505	1684	1860	2032	2200
2400	1642	1837	2029	2216	2400
2600	1779	1990	2198	2401	2600
2800	1915	2143	2367	2586	2800
3000	2052	2296	2536	2770	3000
3200	2189	2449	2705	2955	3200
3400	2326	2602	2874	3140	3400
3600	2463	2755	3043	3325	3600
3800	2599	2908	3212	3509	3800
4000	2736	3061	3381	3694	4000
4200	2873	3215	3550	3879	4200
4400	3010	3368	3719	4063	4400
4600	3147	3521	3888	4248	4600
4800	3283	3674	4057	4433	4800
5000	3420	3827	4226	4617	5000
5200	3557	3980	4395	4802	5200
5400	3694	4133	4564	4987	5400
5600	3831	4286	4733	5172	5600
5800	3967	4439	4902	5356	5800
6000	4104	4592	5071	5541	6000

ELECCIÓN CILINDRO
APLICACIÓN VERTICAL DEL CILINDRO

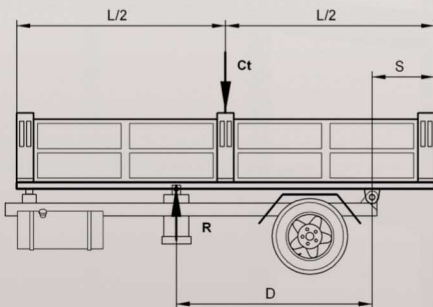

$$R = \frac{Ct \cdot \left(\frac{L}{2} - S\right)}{D}$$

- R = Capacidad del cilindro.
- L = Longitud de la caja.
- S = Longitud voladizo.
- Ct = Carga útil + peso de caja
- D = Distancia entre el perno de basculación y cilindro.

APLICACIÓN INCLINADA DEL CILINDRO

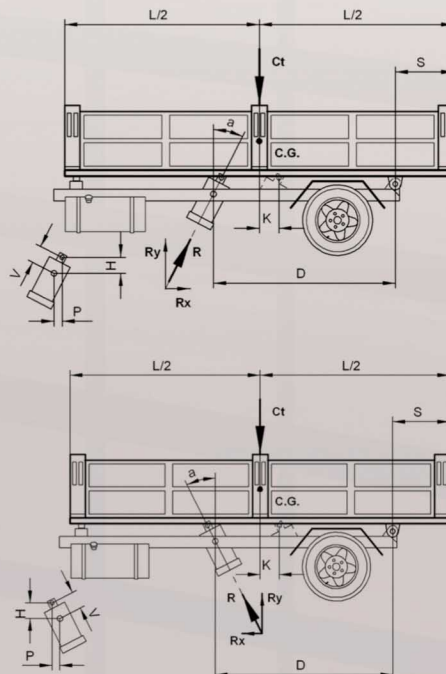

$\alpha \leq 30^\circ$; $K = 100\text{mm}$ max a dx C.G. ;

$$R = \left(\frac{L}{2} - S\right) \frac{Ct \cdot V}{D \cdot H} ; R_x = R \cdot \frac{P}{V}$$

- R = Capacidad del cilindro
- Ry = Fuerza horizontal sobre el perno
- Rx = Fuerza vertical útil.
- L = Longitud de la caja
- S = Longitud del voladizo
- Ct = Carga útil + peso de la caja.
- D = Distancia entre el perno de basculación y el cilindro.
- V = Distancia axial ataque cilindro.
- H = Distancia vertical ataque cilindro.
- P = Distancia horizontal ataque cilindro.

TABLA VERIFICACIÓN CILINDRO

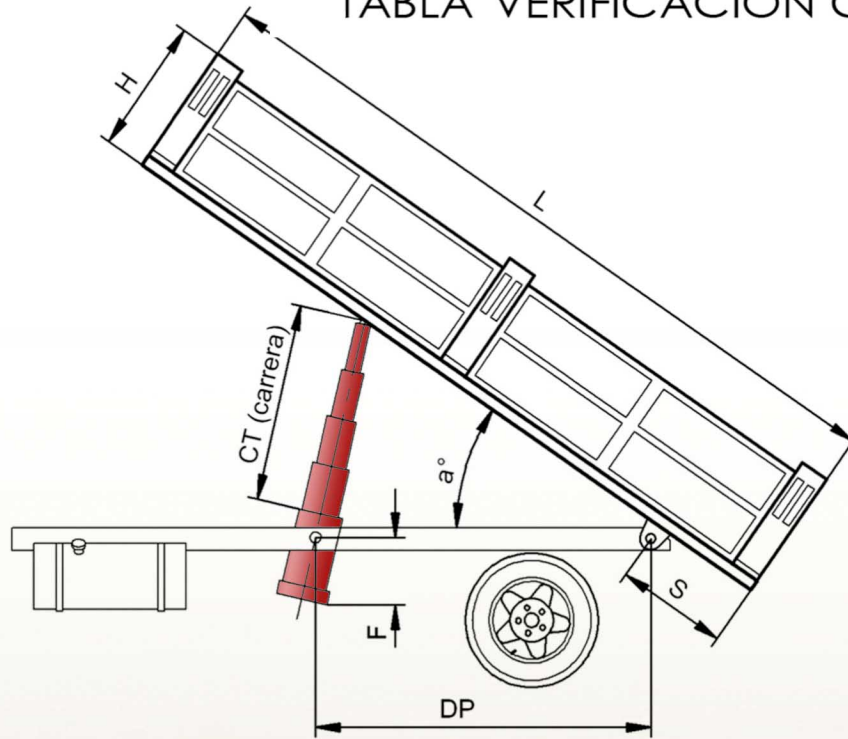

Verificación de un cilindro		Cliente :	
Nº expansiones	Carrera	Ø externo	
Ø expansiones			Tel.
Nota:			Fax
Distancia entre puntos de giro	DP	mm.	Espacio reservado a ArtiTrail Cumplimentado en fecha: <hr/> Para enviar a : <hr/> Para archivar : <hr/> Notas: <hr/> <hr/> <hr/> Firma
Voladizo de la caja	S	mm.	
Longitud de la caja	L	mm.	
Anchura de la caja	La	mm.	
Altura de la caja	H	mm.	
CARRERA SELECCIONADA	CT	mm.	
Dimensiones pistones	F	mm.	
Angulo de inclinación	a°	G°	
Materiale trasportato			
Peso de la caja		Kg.	
Carga útil		Kg.	
Carga total		Kg.	

Comunicando los datos de la tabla, nosotros aconsejaremos el cilindro más adecuado, enviandoles un grafico de la fuerza sobre las expansiones.

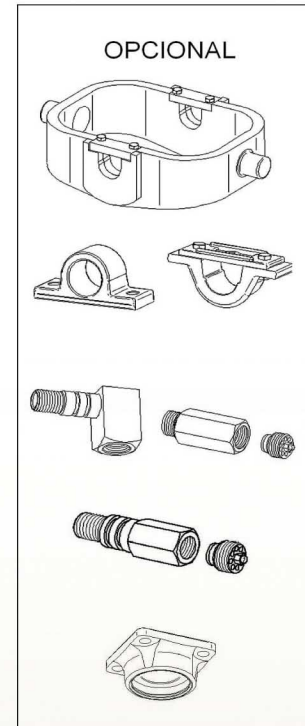
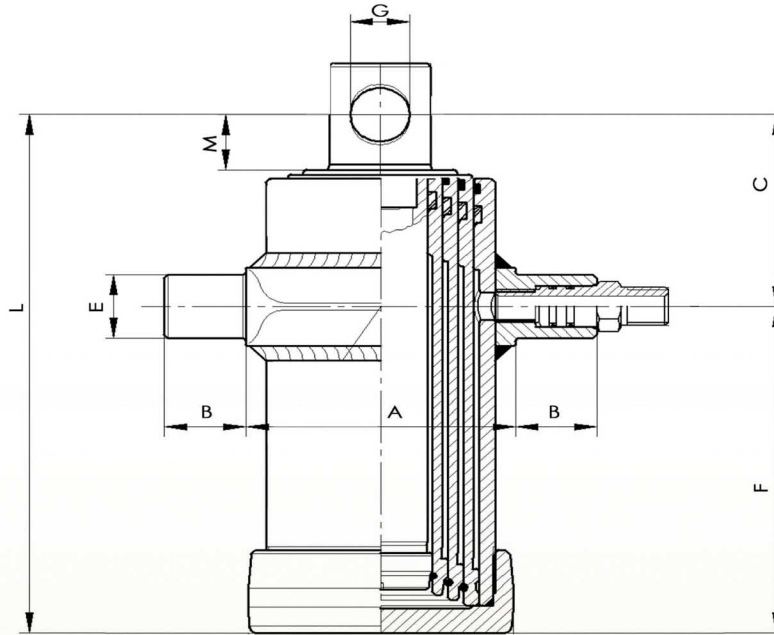

CILINDROS TIPO "F"

CÓDIGO	DESCRIPCIÓN	EXPANSIONES	DIMENSIONES CILINDROS								PESO BRUTO	ACEITE LTRS
			A	B	C	E	F	G	M	L		
CTF001	CT 2X455X80 2020F 3,5tn	46-61	105	40	100	35	240	26	27	340	14	1,1
CTF036	CT 2X525X80 2021F 3,5tn										14,5	1,3
CTF057	CT 2X 595X 80 2022F 3,5tn										15,5	1,5
CTF041	CT 2X595X95 3022F 5,5tn	61-76	115	105	35	310	31	31	32	415	20	2,3
CTF042	CT 2X695X95 3023F 5,5tn										23	2,7
CTF043	CT 2X795X95 3024F 5,5tn										26	3
CTF033	CT 3X683X95 2033F 5tn	46-61-76	135	40	102	35	240	26	32	342	16,5	2,2
CTF049	CT 3X893X112 3034F 8tn	61-76-91									29	4,2
CTF005	CT 3X1043X95 2036F 5tn	46-61-76									21,5	3,3
CTF050	CT 3X1043X112 3035F 8tn	61-76-91	150	40	107	40	365	31	42	472	33	5
CTF051	CT 3X1043X124 4034F 11tn	68-88-107									40	6,6
CTF037	CT 3X1283X112 3036F 8tn	61-76-91									38	6
CTF048	CT 3X1283X124 4035F 11tn	68-88-107	150	40	107	40	445	31	32	552	38	6
CTF064	CT 3X1493X124 4037F 11tn										47	8,2
CTF056	CT 4X910X112 3064F 7tn										46-61-76-91	53
CTF013	CT 4X1040X152 4041F 14tn	68-88-107-126	175	45	130	45	278	36	42	408	48	8,3
CTF009	CT 4X1050X124 3044F 10tn	61-76-91-107									32	6,2
CTF073	CT 4X1060X112 3065F 7tn	46-61-76-91									25,5	4,3
CTF010	CT 4X1190X124 3045F 10tn	61-76-91-107	150	40	112	40	315	31	32	427	34,5	7
CTF016	CT 4X1210X170 4072F 20tn	88-107-126-145									60	13,7
CTF003	CT 4X1220X152 4042F 14tn	68-88-107-126									53,5	9,7
CTF011	CT 4X1290X124 3046F 10tn	61-76-91-107	230	45	112	40	340	31	32	452	37,5	7,5
CTF007	CT 4X1470X190 4082F 25tn	107-126-145-165									86	22,6
CTF045	CT 4X1490X170 4045F 20tn	88-107-126-145									67	16,8
CTF004	CT 4X1500X152 4043F 14tn	68-88-107-126	175	45	130	45	395	36	42	525	61,5	12
CTF039	CT 4X1510X124 3047F 10tn	61-76-91-107									41,5	8,8
CTF008	CT 4X1670X190 4083F 25tn	107-126-145-165									92	25,6
CTF023	CT 4X1690X170 4046F 20tn	88-107-126-145	210	45	200	50	370	36	42	570	74	19
CTF059	CT 4X1700X152 4044F 14tn	68-88-107-126									67,5	13,5
CTF012	CT 4X1710X112 3068F 7tn	46-61-76-91									35,5	6,7
CTF022	CT 4X1710X124 3048F 10tn	61-76-91-107	150	40	112	40	445	26	27	550	35,5	6,7
CTF006	CT 4X1950X190 4048F 25tn	107-126-145-165									100	29,7
CTF032	CT 4X1970X170 4047F 20tn	88-107-126-145									82	22,6
CTF095	CT 4X1990X124 3049F 10tn	61-76-91-107	49,5	11								

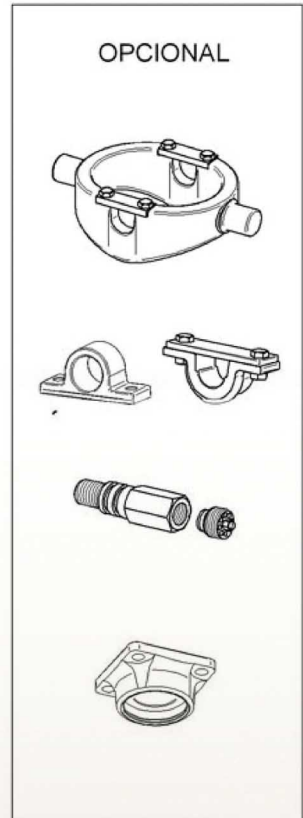
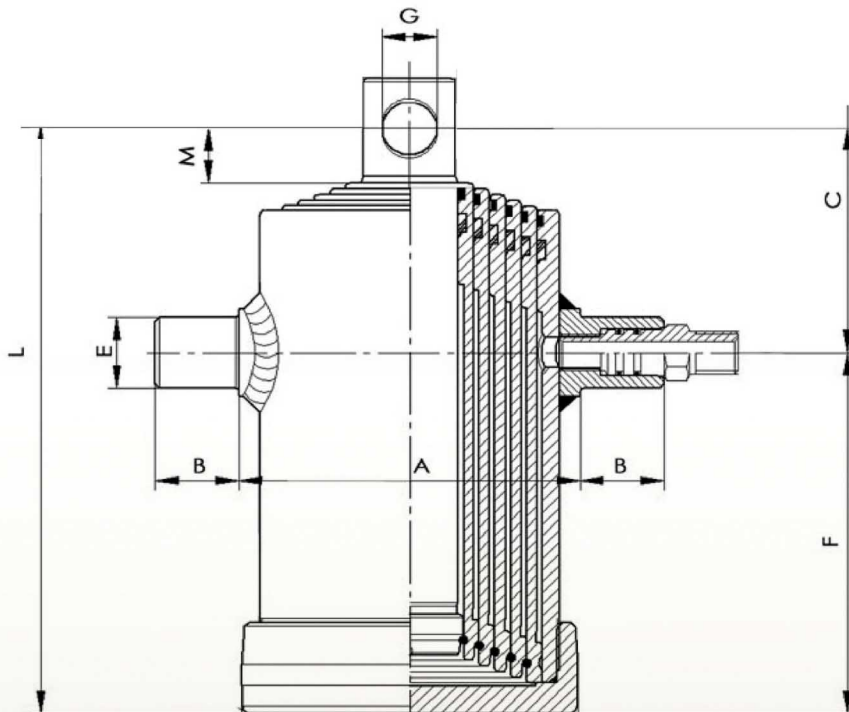

CILINDROS TIPO "F"

CÓDIGO	DESCRIPCIÓN	EXPANSIONES	DIMENSIONES CILINDROS								PESO BRUTO	ACEITE LTRS
			A	B	C	E	F	G	M	L		
CTF046	CT 5X1190X124 3093F 8tn	46-61-76-91-107	150	40	110	40	255	26	27	365	29,5	6
CTF065	CT 5X1480X152 3053F 11tn	61-76-91-107-126	175	45	120	45	315	31	32	435	51,5	11
CTF047	CT 5X1490X124 3094F 8tn	46-61-76-91-107	150	40	110	40		26	27	425	33,5	7,5
CTF002	CT 5X1850X190 5007F 22tn	88-107-126-145-165	230	45	205	50	320	36	42	525	86	25
CTF054	CT 5X1880X152 3054F 11tn	61-76-91-107-126	175		120	45	395	31	32	515	60	13,5
CTF017	CT 5X2100X190 4052F 22tn	88-107-126-145-165	230		205	50	370	36	42	575	92	28,2
CTF014	CT 5X2120X170 4051F 16tn	68-88-107-126-145	210								86	20,6
CTF055	CT 5X2130X152 3055F 11tn	61-76-91-107-126	175		120	45	445	31	32	565	65,5	15,5
CTF018	CT 5X2450X190 4053F 22tn	88-107-126-145-165	230		205	50	440	36	42	655	101	32,8
CTF058	CT 5X2470X170 5002F 16tn	68-88-107-126-145	210							645	95	24
CTF038	CT 5X2480X152 3056F 11tn	61-76-91-107-126	175		120	45	515	31	32	635	73,5	18
CTF066	CT 5X2990X170 5015F 16tn	68-88-107-126-145	210		205		570			775	114	29
CTF067	CT 5X2990X190 5011F 22tn	88-107-126-145-165	230					36	42		118	40
CTF070	CT 6X2225X190 4060F 20tn	68-88-107-126-145-165				208	50	325			533	100
CTF025	CT 6X2950X190 4062F 20tn									653	123	34,6
CTF028	CT 6X2965X170 6024F 13tn	61-76-91-107-126-145	210		195		440	31	31	635	93	26
CTF060	CT 6X2977X152 6012F 9tn	46-61-76-91-107-126	175		115	45	515	26	27	630	68	19

Amarres especiales.

CTF061	CT 3X1130X152 D11560 16 tn	88-107-126	175	45	197	45	312	36	42	509	40	11
CTF035	CT 3X1273X152 4036E 16tn					373	570			53	12	
CTF021	CT 3X1283X124 4035E 11tn	68-88-107	150	40		40	365			562	45,6	8,2
CTF020	CT 4X1040X152 4041E 14tn	68-88-107-126	175	45	199	45	209			408	48	8,3
CTF099	CT 4X1190X124 3045E 10tn	61-76-91-107	150	40	189	40	238	31	32	427	34,5	7
CTF027	CT 4X1220X152 4042E 14tn	68-88-107-126	175	45	199	45	256	36	42	455	53,5	9,7
CTF031	CT 4X1500X152 4043E 14 tn					326	525	61,5	12			
CTF044	CT 4X1510X124 3047E 10tn	61-76-91-107	150	40		40	308	31	32	507	41,5	8,8
CTF089	CT 4X1700X152 4044E 14tn	68-88-107-126	175	45		45	376	36	42	575	67,5	13,5

* nº expansiones x carrera x Ø botella. Código origen y capacidad media en tons. A 180 bars de presión.

Cilindros habitualmente en stock. Consulten otras medidas u opciones

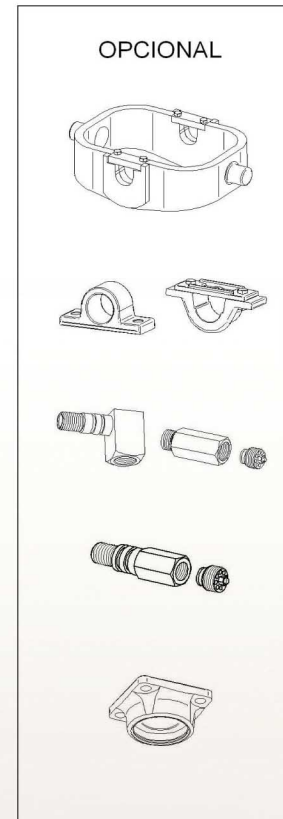
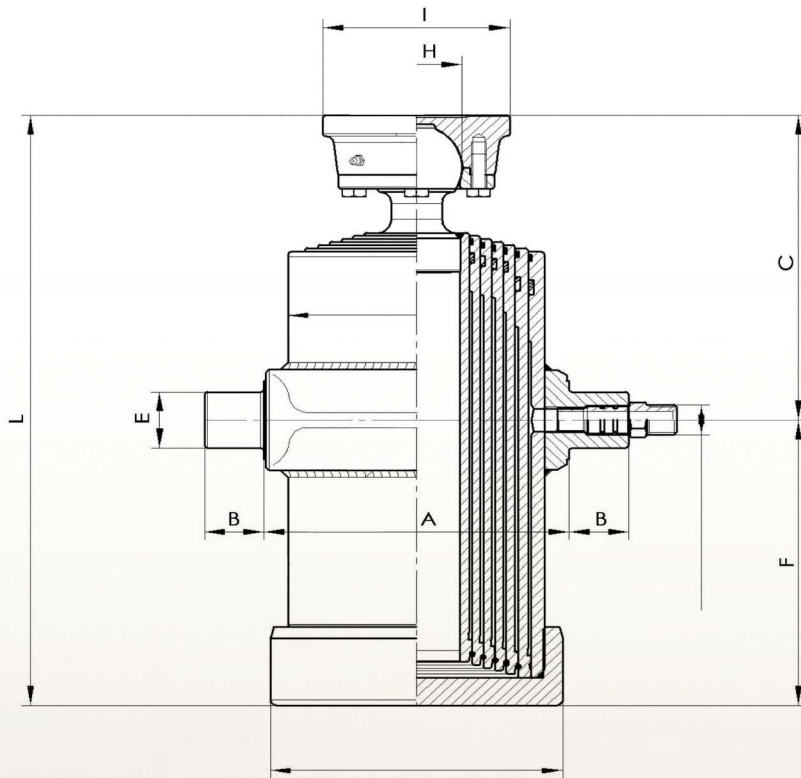

CILINDROS TIPO "R"

CÓDIGO	DESCRIPCIÓN	EXPANSIONES	DIMENSIONES CILINDROS							PESO BRUTO	ACEITE LTRS	
			A	B	C	E	F	H	I			L
CTR001	CT 2X 455X 80R 2020S 3,5tn	46-61	105		140		240	45	112	380	1,1	15,5
CTR007	CT 2X 795X95R 3024S 5,5tn	61-76			150		410	55	95	560	3	28
CTR002	CT 3X 593X95R 2032S 5tn	46-61-76	115	40	142	35	210	45	112	352	2	16,5
CTR003	CT 3X 683X 95R 2033S 5tn						240			382		
CTR011	CT 3X1043X112R 3035S 8tn	61-76-91	135		152		365			517	5	35
CTR009	CT 3X1283X112R 3036S 8tn						445			55		
CTR008	CT 4X1050X124R 3044S 10tn	61-76-91-107	150		157	40	280			437	6,2	33,5
CTR012	CT 4X1500X152R 4043S 14tn	68-88-107-126	175	45	162	45	395			557	12	63
CTR014	CT 5X1190X124R 3093S 8tn	46-61-76-91-107	150	40	150	40	255	45	112	405	6	31
CTR023	CT 5X1480X152R 3053S 11tn	61-76-91-107-126	175	45	165	45	315	55	95	480	11	53
CTR010	CT 5X1490X124R 3094S 8tn	46-61-76-91-107	150	40	150	40	315	45	112	465	7,5	35
CTR038	CT 5X1880X152R 3054S 11tn	61-76-91-107-126	175	45	165	45	395	55	95	560	13,5	61,5
CTR040	CT 5X2480X152R 3056S 11tn						515			680		
CTR018	CT 5X2925X215R 5037S 29tn	107-126-145-165-187	250	50	258	50	575	73	150	833	51	171
CTR035	CT 6X2245X170R 6022S 13tn	61-76-91-107-126-145	210	45	240		320	55	95	560	19,8	78
CTR041	CT 6X2977X152R 6012S 9tn	46-61-76-91-107-126	175		155	45	515	45	112	670	19	69,5
CTR015	CT 6X3565X215R 6057S 25tn	88-107-126-145-165-187	250	50	260	50	575	73	150	835	56	171
CTR044	CT 8X3330X215R 8025S 18tn	61-76-91-107-126-145-165-187					375					
CTR068	CT 8X3815X240R 8017S 25tn	68-88-107-126-145-165-187-210	275		255	55	455	73	150	710	61	214
CTR019	CT 8X3890X215R 8027S 18tn	61-76-91-107-126-145-165-187	250		260	50	445	65	107	705	49	178

* n° expansiones x carrera x Ø botella. Código origen y capacidad media en tons. A 180 bars de presión.

Cilindros habitualmente en stock. Consulten otras medidas u opciones

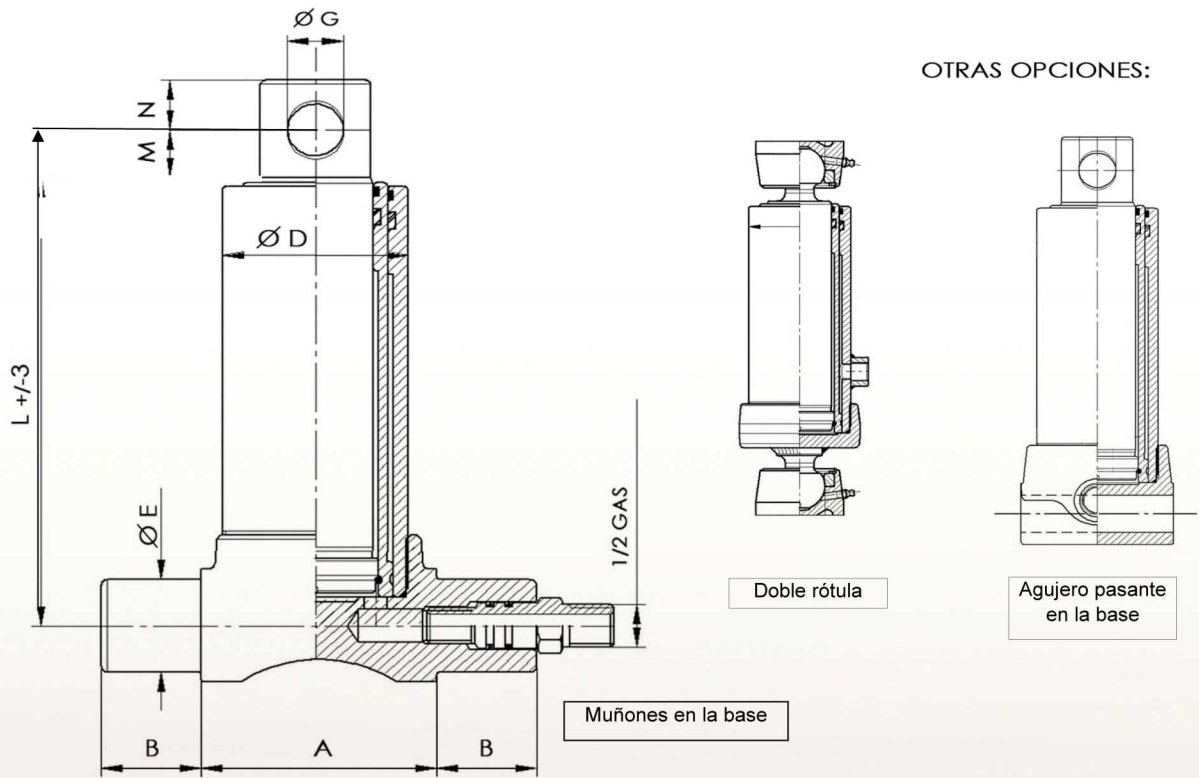

CÓDIGO	DESCRIPCIÓN	EXPANSIONES	DIMENSIONES CILINDROS						PESO BRUTO	ACEITE LTRS	
			A	B	E	G	M	N			L
Agujero pasante en la base											
CTB037	CT 2X 455X 80/AP 2620F 3,5tn	46-61	115	31	NA	26	27	25	340	12	1,1
CTB033	CT 2X 595X 80/AP 2622F 3,5tn	61-76				31	32	30	425	20	2,3
CTB029	CT 2X 595X 95/AP 3622F 5,5tn	46-61				26	27	25	510	19	2
CTB049	CT 2X 795X 80/AP 2624F 3,5tn	46-61-76				36	42	30	352	15,5	2,2
CTB028	CT 3X 683X 95/AP 2633F 5tn	68-88-107	150			498	40	6,6			
CTB032	CT 3X1043X124/AP 4634F 11tn					578	47	8,2			
CTB025	CT 3X1283X124/AP 4635F11tn										
Muñones en la base											
CTB009	CT 2X455X80/GB 2520F 3,5tn	46-61	105	45	45	26	27	25	340	14	1,1
CTB035	CT 2X 525X 80/GB 2521F 3,5tn	46-61-76	115			31			377	18	2,5
CTB001	CT 3X 790X 95/GB 2534F 5tn	61-76-91	135			26	412	19,5	2,8		
CTB017	CT 3X 893X 95/GB 2535F 5tn					31	422	31	4,2		
CTB021	CT 3X 893X112/GB 3534F 7,5tn	61-76-91	135	31	32	472	33	5			
CTB007	CT 3X1043X112/GB 3535F 7,5tn	68-88-107	150	36	42	552	38	6			
CTB050	CT 3X1283X112/GB 3536F 7,5tn	61-76-91-107	175	31	32	392	32	6,2			
CTB056	CT 3X1283X124/GB 4535F 11tn	68-88-107-126	175	36	42	455	53,5	9,7			
CTB008	CT 4X1050X124/GB 3544F 10tn			31	32	452	37,5	7,5			
CTB003	CT 4X1220X152/GB 4542F 14tn			31	32	507	43	8,8			
CTB004	CT 4X1290X124/GB 3546F 10tn	61-76-91-107	150	31	32	557	46,5	10			
CTB043	CT 4X1510X124/GB 3547F 10tn					627	49,5	11			
CTB040	CT 4X1710X124/GB 3548F 10tn										
CTB041	CT 4X1990X124/GB 3549F 10tn										

* n° expansiones x carrera x Ø botella. Código origen y capacidad media en tons. A 180 bars de presión.

Cilindros habitualmente en stock. Consulten otras medidas u opciones

ACCESORIOS PARA CILINDROS

SOPORTES PARA CILINDROS

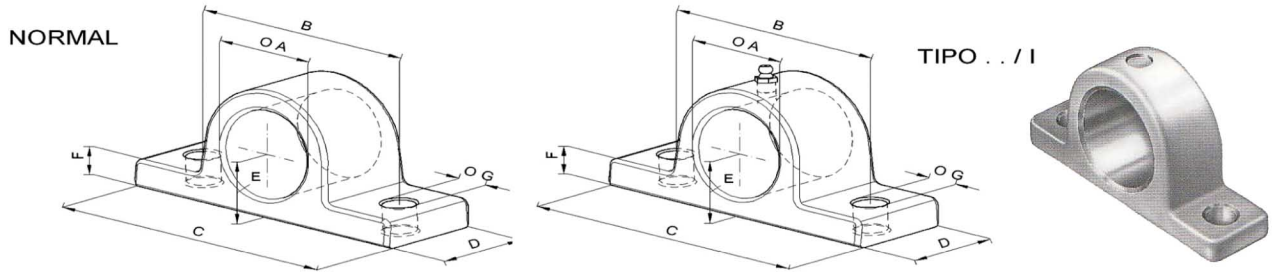

Materiale: Acero forjado UNI Fe 510 -

TIPO	DIMENSIONES								PESO Kg
	Ø A	B	C	D	E	F	Ø G		
SOPØ35	35,5	95	130	45	30	12	13		1
SOPØ40	40,5	105	140	45	33	15	15		1,2
SOPØ45	45,5	105	140	45	33	15	15		1,2
SOPØ50	50,5	120	155	50	37	17	15		1,5
SOPØ55	55,5	120	155	55	37	17	15		1,5

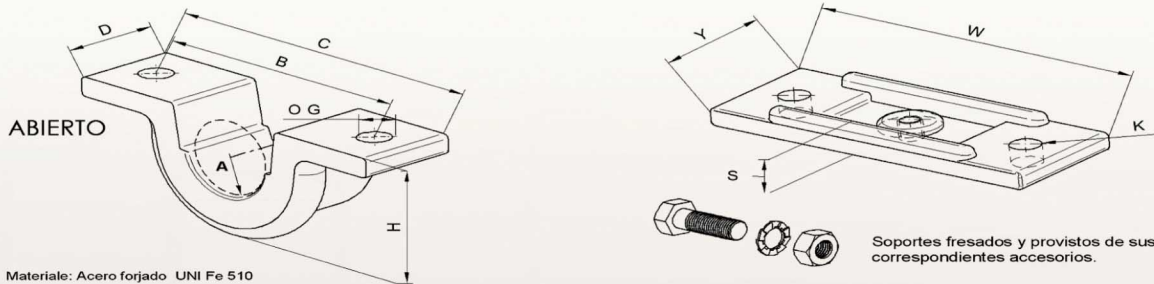

Materiale: Acero forjado UNI Fe 510

TIPO	DIMENSIONES										PESO Kg POIDS WEIGHT Kg GEWICHT Kg
	Ø A	B	C	D	Ø G	H	W	Y	Ø K	S	
SOP.ABT Ø40	40,5	112	140	40	13	62	140	40	13	8	1
SOP.ABT Ø45	45,5	112	140	40	13	62	140	40	13	8	1,2
SOP.ABT Ø50	50,5	115	185	60	13	82	150	56	13	17	2,5
SOP.ABT Ø55	56	115	190	60	13	86	150	56	13	17	2,6
SOP.ABT Ø70	71	148	210	60	13	100	170	60	13	17	3,6

SOPORE OSCILANTE PARA ANCLAJE DE CILINDRO

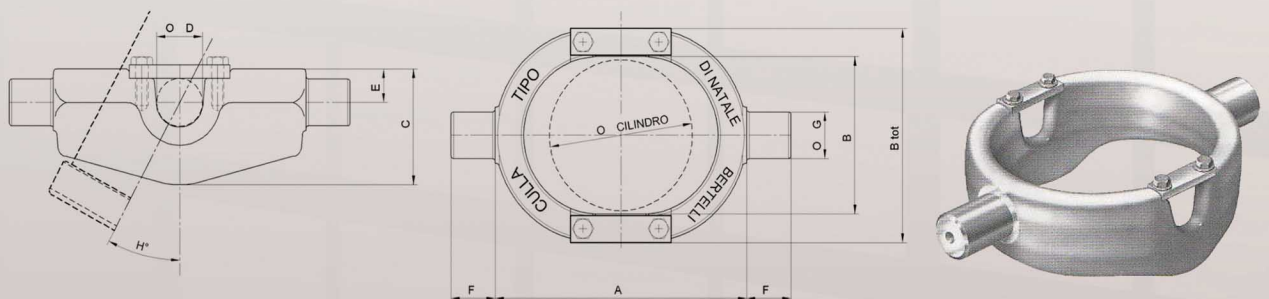

TIPO	DIMENSIONES										CAPACIDAD Ton.	PESO Kg
	A	B	B tot.	C	Ø D	E	F	Ø G	H	Ø Cil.		
SPT.OSC 1	200	120	160	77	35	25	35	35	32°	80/95	7 Ton.	5
SPT.OSC 2	230	135	195	97	35	28	40	40	37°	112	10 Ton.	9
SPT.OSC 3	230	155	215	107	40	31	40	40	30°	124	16 Ton.	10,5
SPT.OSC 4	280	185	240	125	45	40	45	50	30°	150	20 Ton.	15
SPT.OSC 5	330	215	290	165	50	45	55	50	30°	170	22 Ton.	22
SPT.OSC 6	390	235	310	205	50	65	55	50	30°	190	23 Ton.	29
SPT.OSC 7	400	255	350	205	50	65	55	50	30°	215	25 Ton.	32

ACCESORIOS PARA CILINDROS

ROTULAS Y ASIENTOS

UNION CUADRADA

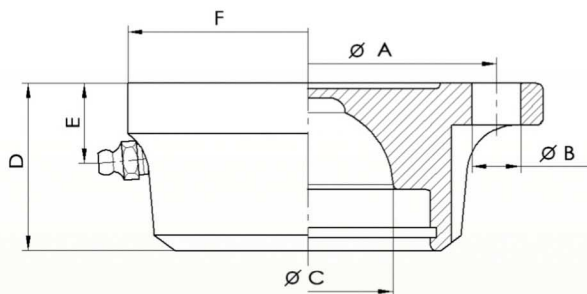

TIPO	A	B	C	D	E	F	CAPACIDAD	PESO Kg
Ø 45	100	13	45	44	21	95x95	11 TN	1,8
Ø 55	125	14	55	55	26	125x125	15 TN	2
Ø 65	150	14	65	58	29	140x140	23 TN	3

ROTULA DE UNION

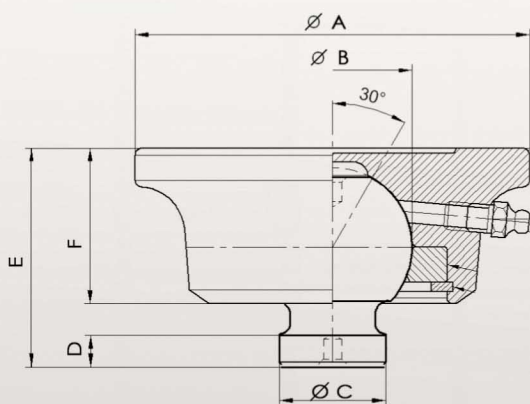

TIPO	A	B	C	D	E	F	CAPACIDAD	PESO Kg
Ø 45	112	45	30	9	62	44	11 TN	2,2
Ø 55	95	55	45	8	78	55	15 TN	3
Ø 65	108	65	65	9	88	58	23 TN	4

ROTULAS Y ASIENTOS

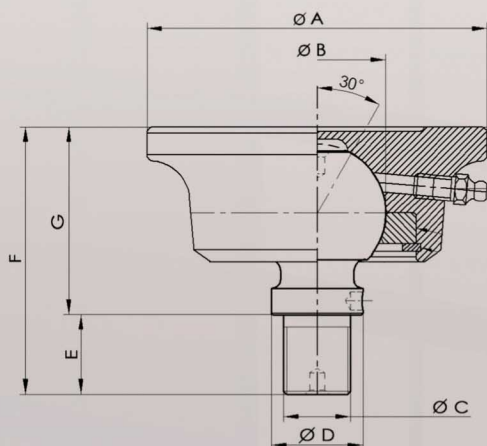

ROTULA DE UNIÓN ROSCADA

TIPO	A	B	C	D	E	F	G	CAPACIDAD	PESO Kg
Ø 45	112	45	22x1,5	30	26	87	61	11 TN	3,2
Ø 55	95	55	32x2	45	35	112	77	15 TN	4,3
Ø 65	108	65	40x2	50	30	127	87	23 TN	4,8

ACCESORIOS PARA CILINDROS

PERNOS PARA ENTRADA DE ACEITE

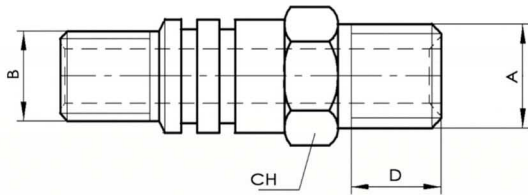

TIPO	CÓDIGO	A	B	D	CH
Ø 23 - 1/2 GAS - M - UNI 338-66	07000000	1/2 Gas	M18 x 1,5	20	24
Ø 25 - 3/4 GAS - M - UNI 338-66	26100000	3/4 Gas	M22x1,5	22	27
Ø 30 - 1" GAS - M - UNI 338-66	26700000	1" Gas	M28x1,5	23	36

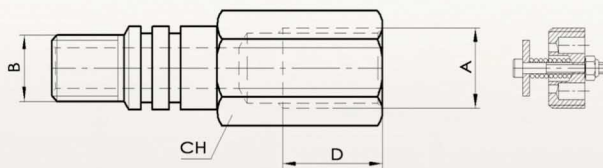

TIPO	CÓDIGO	A	B	D	CH
Ø 23 - 1/2 GAS - F - UNI 338-66	71730000	1/2 Gas	M18 x 1,5	30	27
Ø 25 - 3/4 GAS - F - UNI 338-66	71560000	3/4 Gas	M22 x 1,5	40	36

CON VÁLVULA DE BLOQUEO

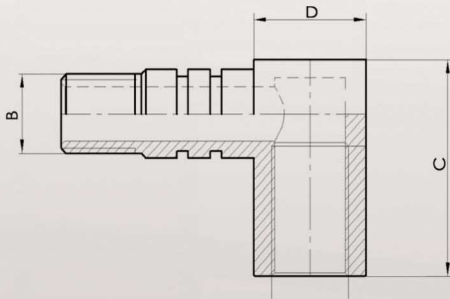

TIPO	CÓDIGO	A	B	D	C
Ø 25 - 3/4 GAS - F - UNI 338-66	26320000	3/4 Gas	Ø 22 x 1,5	35	60
Ø 30 - 1" GAS - F - UNI 338-66	26790000	1" Gas	Ø 28 x 1,5	40	60

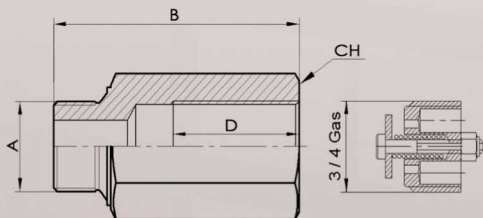

Válvula tarada a 150 lf./min, y A 210 lf./min

TIPO	CÓDIGO	A	B	D	CH
Ø 3/4 GAS M - O 3/4 GAS F	27230000	Ø 3/4 Gas	78	40	36
Ø 1" GAS M - O 1" GAS F	27240000	1" GAS	100	50	42

CON VÁLVULA DE BLOQUEO

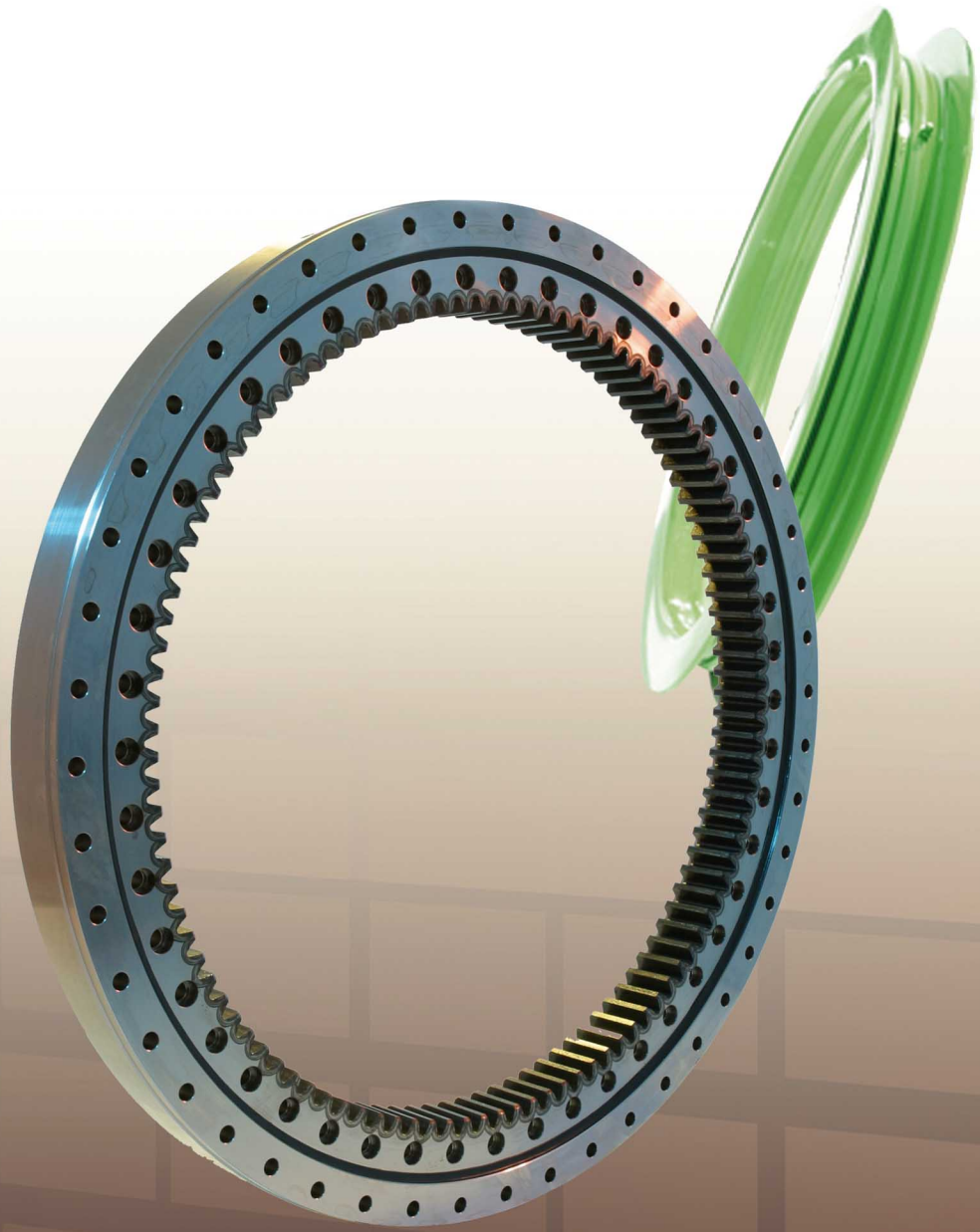

RODETES, CORONAS Y GRUPOS SINFIN

LA LEONESSA

La Leonessa S.P.A., fundada en 1965, está centrada en el desarrollo, diseño y fabricación de coronas de orientación para aplicación industrial.

Gracias a la instalación de una planta de forjado de anillos sin costuras, La Leonessa se convierte en un fabricante de ciclo completo, todas las fases de producción son internas y bajo el control de La Leonessa.



SEGMENTOS DE MERCADO

EQUIPOS DE CONSTRUCCIÓN



gruas torre



movimientos tierra



equipos perforación



bombas hormigón

ELEVACIÓN Y MOVIMIENTO



manipulador telescópico



carretillas



plataformas aéreas



forestal

PROCESO INDUSTRIAL



pulpa y papel



embotellado



embalaje



espesantes

PROCESO INDUSTRIAL



propulsores

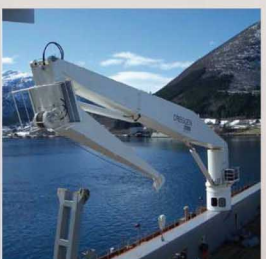

grúas cubierta



cabestrantes



brazo de carga

GENERACIÓN ENERGÍA



aerogeneradores



seguidores solares



antenas



tratamientos aguas

OTROS

RODETES LA LEONESA

TIPOS

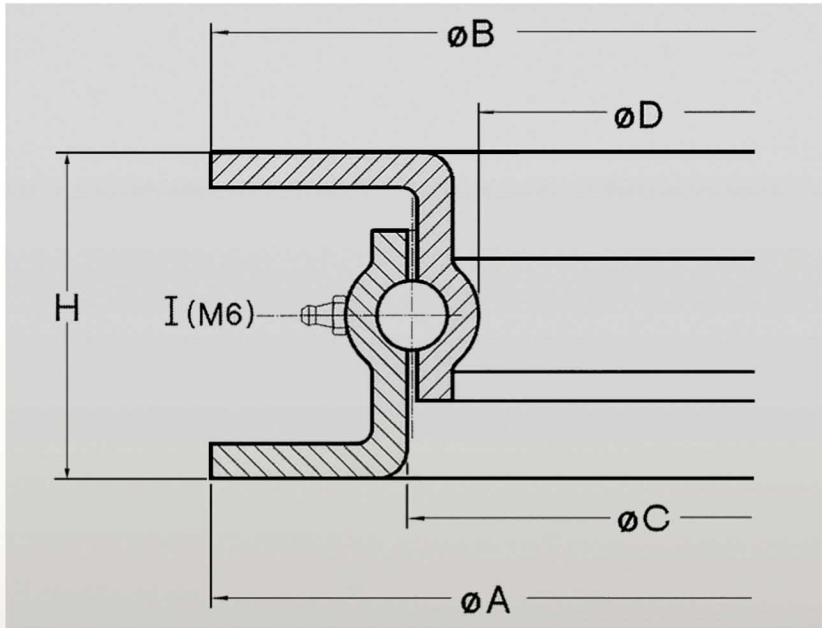

CÓDIGO/REFERENCIA	mm					Nº	BOLA	PESO	CARGA AXIAL
	H	A	B	C	D				
L ROD009/RODETE LU 300	55	298	293	220	200	1	ø 12	5	0,5
ROD001/RODETE LU 400	55	400	400	320	300	1	ø 12	8	0,75
ROD002/RODETE LU 500	55	500	500	420	400	1	ø 12	10	1
N ROD003/RODETE NU 600	65	600	600	516	490	2	ø 14	18	1,7
* /RODETE NU 650	65	650	650	568	543	2	ø 14	20	1,7
ROD004/RODETE NU 700	65	700	700	620	594	2	ø 14	22	2,2
* /RODETE NU 750	65	750	750	668	640	2	ø 14	24	2,2
ROD005/RODETE NU 800	65	800	800	718	690	2	ø 14	26	2,5
* /RODETE NU 850	65	850	850	767	742	2	ø 14	28	3
ROD006/RODETE NU 900	65	900	900	820	793	2	ø 14	30	3,5
* /RODETE NU 950	65	950	950	870	843	2	ø 14	31	3,5
ROD007/RODETE NU 1000	65	1000	1000	920	895	2	ø 14	33	4
ROD010/RODETE NU 1050	65	1050	1050	970	945	2	ø 14	35	4,5
P * /RODETE PU 900	80	890	895	795	766	2	ø 16	36	5
* /RODETE PU 1000	80	1010	1015	916	888	2	ø 16	42	6
ROD008/RODETE PU 1100	80	1100	1105	1005	976	2	ø 16	45	6,5
T * /RODETE TU 1000	90	1000	1008	889	856	2	ø 20	60	8
ROD011/RODETE TU 1100	90	1100	1100	980	948	2	ø 20	65	10

* Medidas menos habituales. Consultar disponibilidad.

APLICACIONES Y CONDICIONES DE SUMINISTRO

Los rodets de bolas para dirección "La Leonessa" son utilizados para las más variadas aplicaciones, entre las más importantes podemos citar los remolques y maquinaria agrícola, transporte aeroportuario,...

En aplicaciones sobre vehículos los rodets soportan tanto una carga axial como una carga radial, al contrario de otras aplicaciones que sólo soportan cargas axiales. Los rodets de la serie L están diseñados para velocidad hasta 25 km/h, Por el contrario las series N,P, T pueden ser usados para velocidades hasta 40 km/h. La carga axial reflejada en la lista anterior está determinada para una velocidad de 25 km/h. Esta carga axial variará en función de que la velocidad aumente o disminuya. Estamos a su disposición para cualquier consulta respecto a la determinación de la carga admisible.

Los rodets son entregados con una protección antioxidante negra y salen de fábrica ya engrasados y provistos de engrasador. Los rodets se suministran sin los agujeros para los tornillos de fijación. Podemos estudiar los lotes mínimos y precios para la entrega de los rodets con los agujeros personalizados según necesidades del cliente.

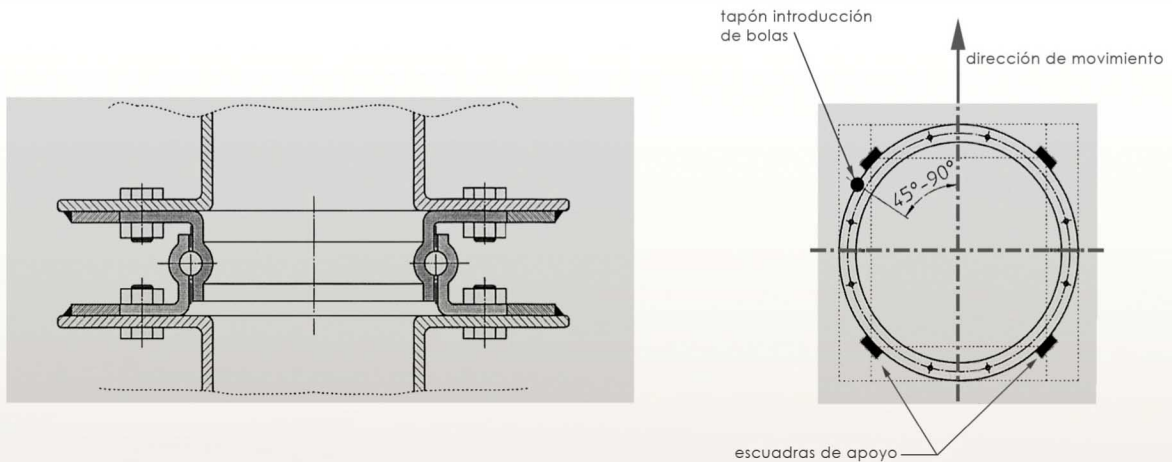

MONTAJE Y MANTENIMIENTO

Los rodets deben ser fijados a la estructura con tornillos.

Para una correcta fijación, es importante que la superficie de apoyo sea lo más plana e rígida posible, que apoye al menos el 50 % en dicha superficie y que sea distribuida de forma simétrica respecto a la dirección del movimiento.

Se debe evitar realizar los agujeros en correspondencia con el tapón de introducción de las bolas, reconocible por la soldadura en la pista del anillo externo. Este tapón deberá estar entre los 45° - 90° respecto a la dirección del movimiento.

Para la fijación del rodete se deben utilizar tornillos de calidad mínima 8,8.

Es necesaria la incorporación de 8 escuadras, (4 por lado) soldadas a la estructura del apoyo, que permiten descargar a los tornillos de la fuerza radial producida por las aceleraciones y desaceleraciones.

No es admisible la fijación mediante soldadura del rodete a la estructura.

Antes de proceder al montaje, engrasar una segunda vez haciendo girar el rodete al mismo tiempo.

La frecuencia del engrasado debe ser programada en función de las condiciones de trabajo, aunque de media debe realizarse una vez al mes.

TORNILLOS DE FIJACIÓN			
TIPO DE RODETE	TORNILLOS	TORNILLOS	
		CALIDAD	TUERCA
L-300-400-500-600	M12	8,8 min	EXAGONAL o AUTO-BLOCANTE
N-600-650-700-750	M12-M14		
N-800-850-900-950 N-1000-1050	M14-M16		
P-900-1000-1100 T-1000-1100			

TIPO **SG**

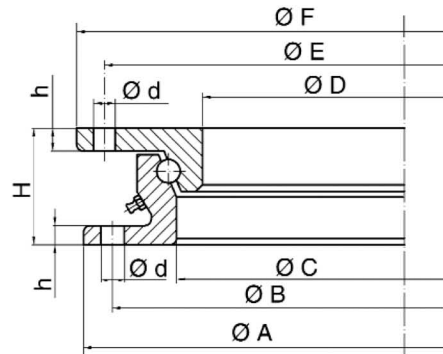

DATOS TÉCNICOS

Tipo	Código	Perforada	Carga Axial	A mm	B mm	C mm	D mm	E mm	F mm	d mm	h mm	H mm	Peso :
SG	RSG0810	NO	8	1000	960	877	846	974	1008	18	10	90	73
	RSG1010	NO	10	1000	960	877	846	974	1008	18	10	90	73
	RSG1011	SI	10	1100	1060	977	946	1074	1108	18	10	90	80
	RSG1211	SI	12	1100	1060	977	946	1074	1108	18	10	90	80
	RSG1312	SI	13	1200	1160	1077	1046	1174	1208	18	10	90	87
	RSG1510	NO	15	1000		829	846		987		14	63	60

TIPO **SW**

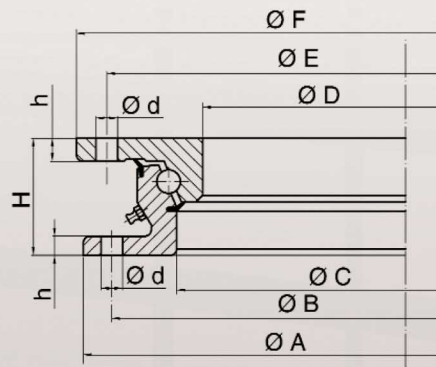

BAJO MANTENIMIENTO

DATOS TÉCNICOS

Tipo	Código	Perforada	Carga Axial	A mm	B mm	C mm	D mm	E mm	F mm	d mm	h mm	H mm	Peso :
SW	RSW0810	NO	8	1000	960	877	846	974	1008	18	10	90	73
	RSW1010	NO	10	1000	960	877	846	974	1008	18	10	90	73
	RSW1011	SI	10	1100	1060	977	946	1074	1108	18	10	90	80
	RSW1211	SI	12	1100	1060	977	946	1074	1108	18	10	90	80
	RSW1312	SI	13	1200	1160	1077	1046	1174	1208	18	10	90	87

TIPO **DG**

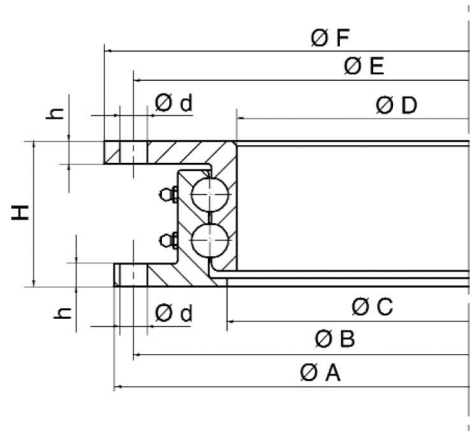

DATOS TÉCNICOS													
Tipo	Código	Perforada	Carga Axial	A mm	B mm	C mm	D mm	E mm	F mm	d mm	h mm	H mm	Peso :
DG	RDG1610	SI	16	1000	966	834	871	952	987	18	14	90	92
	RDG2011	SI	20	1100	1074	940	975	1060	1096	18	15	92	96
	RDG3010	SI	30	1000	962	827	881	952	987	18	15	95	104

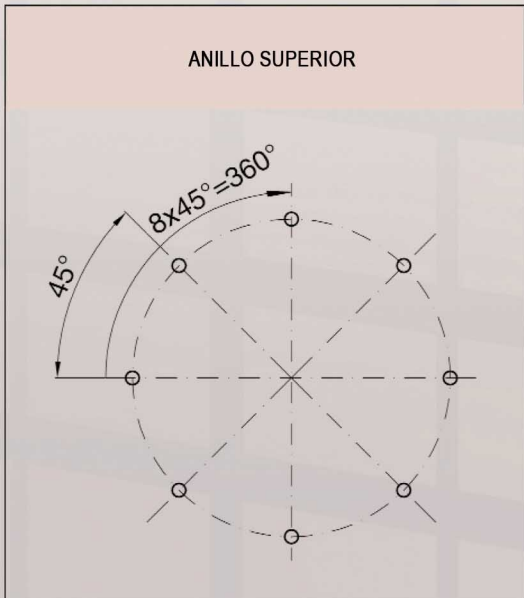
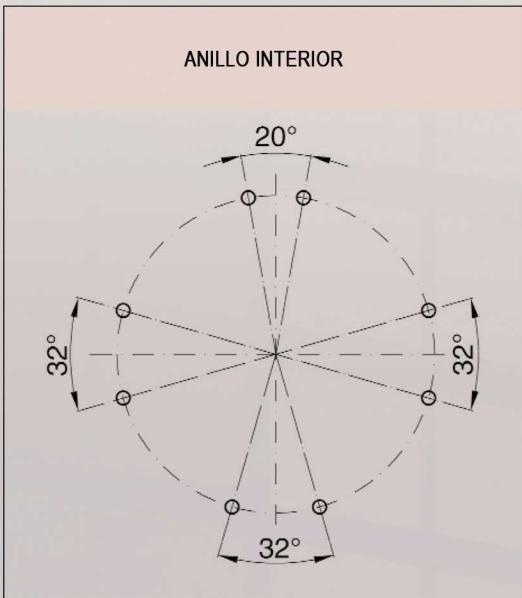

TIPOLOGÍA CONSTRUCTIVA:



CORONAS MÁS HABITUALES:

Código	Diámetro		Altura	Módulo	nº dientes	Peso
	Externo	Interno				
DENTADURA EXTERNA						
COR023 VE031A01	318	156	55	4,5	69	16,4
COR002 VE040A01	403,5	235	55	4,5	88	30
COR007 VE064A06	640	471	56	5	126	60
COR064 VE064A08	640	471	56	6	105	45
COR069 VE064A09	642	434	58	6	105	60
COR075 V25E244	800	569	85	10	78	110
COR018 V30E081	816	570	90	8	100	90
COR020 VE097A00	972	764	70	6	160	95
COR028 VE120A05	1200	976	65	8	148	140
COR015 V30E088	1289,5	984	114	10	125	180
COR065 VE138B04	1380	1095	108	10	136	350
DENTADURA INTERNA						
COR027 VI057A01	570	378	63	6	65	45
COR016 VI075A11	750	546	63	6	93	75
COR012 VI095A14	950	736	63	8	94	110
COR021 V25I020	976	786	82	8	100	120
COR022 V25I040	1170	962	90	10	98	180
COR019 VI120B01	1200	963,5	110	10	98	247
COR066 VI147A00	1470	1183	108	10	120	350
SIN DENTADURA						
COR056 VS030A00	305	156	55	-	-	10
COR068 VS040A00	403,5	235	55	-	-	25
COR006 VS051A03	518	304	56	-	-	39
COR071 V18S074	589,5	383	75	-	-	58

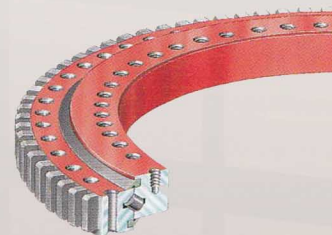
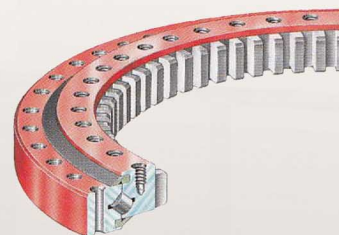

ANILLOS LAMINADOS SIN COSTURA

Anillos desde 400mm. hasta los 2000mm. de diámetro exterior.

Pesos desde 30 Kg hasta 600 Kg.

Aceros habituales C45 y 42 CrMo4.



FICHA DE SOLICITUD

EMPRESA::				
Teléfono:		Fax:		E-mail:
<input type="checkbox"/> Constructor	<input type="checkbox"/> Comercial	<input type="checkbox"/> Recambista	Otro:	
APLICACIÓN (descripción)				
Posición eje de rotación		Rotación de:		Velocidad de rotación:
Vertical <input type="checkbox"/> Horizontal <input type="checkbox"/>		Posicionamiento <input type="checkbox"/> Continua <input type="checkbox"/>		
Las cargas actúan:		Temperatura de ejercicio:		Ambiente
Compresión <input type="checkbox"/> Tracción <input type="checkbox"/>				
CARGA SOBRE LA CORONA				
Carga Axial				
Carga Radial				
Fuerza s/ Dentadura		Nº de Piñones		
DIMENSIÓN REQUERIDA				
Diámetro externo máximo		Dentadura Interna <input type="checkbox"/> Externa <input type="checkbox"/> Sin <input type="checkbox"/>		
Otros datos, diseño de la aplicación:				

TRANSPORTE Y EMPAQUETADO

Las coronas de orientación de LaLeonesa han de ser transportadas y manejadas en su posición horizontal, evitando cualquier impacto o daño, especialmente en su dirección radial. Al ser un componente de una maquinaria, han de ser manejadas cuidadosamente. El empaquetado de este producto se efectúa en Europallets, asegurado y protegido con un film de aceite anticorrosivo. Este film protege la superficie del producto durante al menos 6 meses, siempre y cuando se almacene en un lugar cerrado, protegido del exterior. Cuando las coronas se desempaquetan hay que tener cuidado de no dañar las guarniciones. Para desengrasar el producto hay que usar disolventes comerciales, teniendo cuidado de que estos no ataquen las guarniciones o entren dentro de las pistas de rodamiento. Se recomienda no usar disolventes que contengan cloruro y que puedan dañar la superficie.

POSICIONAMIENTO DE LA CORONAS

Para asegurarse de un adecuado posicionamiento y para garantizarles una eficiente y larga vida, siempre han de respetarse las marcas hechas en las coronas.

ENLACE DE INICIO Y UNION FINAL

Sobre el anillo dentado es reconocible una letra "T", estampada en una cara. El anillo no dentado deberá encontrarse en correspondencia con el tapón de introducción de los elementos giratorios. En fase de montaje es necesario asegurarse que los puntos de enlace se encuentren en la zona no sujeta a la carga máxima.

EXCENRICIDAD DE LA DENTADURA

Se destacan tres dientes pintados de rojo y en la fase de montaje es necesario asegurarse la correspondencia entre estos tres dientes con el hueco entre los dientes de la rueda y los del piñón sea de al menos 0,05 mms. por el módulo de la dentadura.

ENGRASADORES

Las coronas de orientación están provistas de un adecuado número de agujeros para el engrasado. Los agujeros deben encontrarse en posición fácilmente accesible.

MANTENIMIENTO

Las pistas de rodamiento deben ser lubricadas en intervalos, que dependen de las condiciones de uso. Recomendamos engrasarlas después de las primeras 50 horas de uso y luego cada 100 horas. Antes y después de un largo periodo de inactividad las coronas deben ser engrasadas de nuevo. La grasa es bombeada mientras la corona gira y se considera completa cuando empieza a rebosar de la guarnición formando un suave film que sirve de protección. Si no se puede efectuar este control visual nuestra oficina técnica les indicará cuanta grasa usar. Esta grasa debe ser esparcida sobre la dentadura y la debe cubrir íntegramente. Cuando no es posible controlar visualmente la presencia de grasa recomendamos engrasar cada tres o seis meses de acuerdo con el uso de la máquina.

CB-E-437

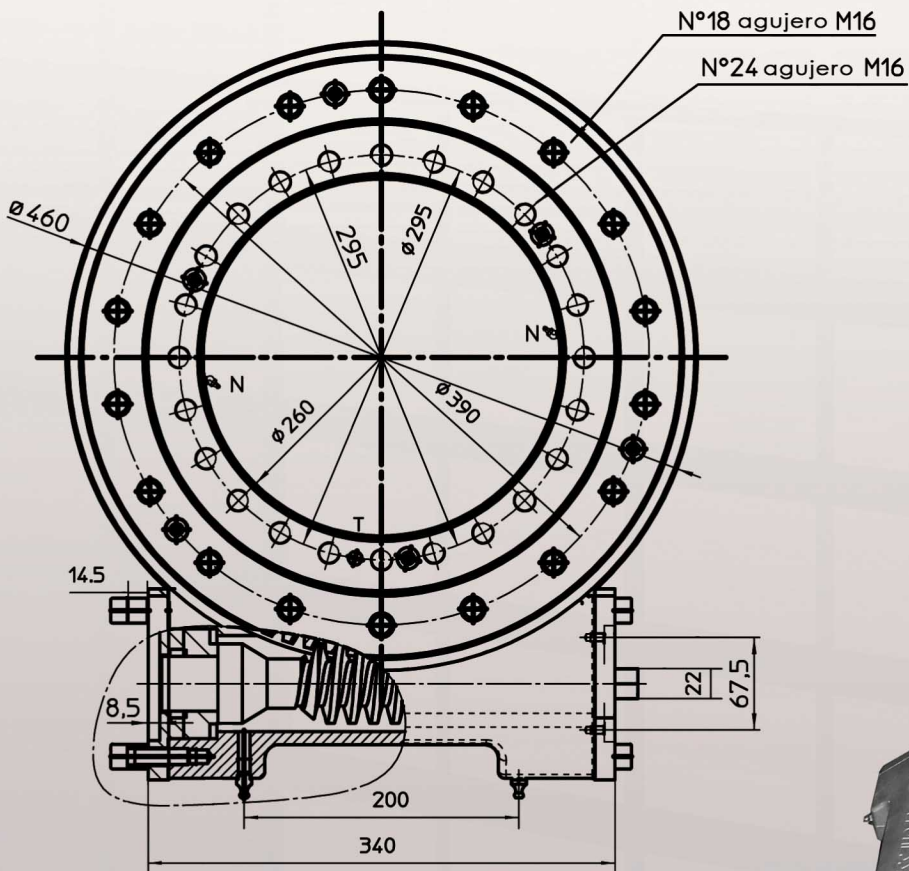
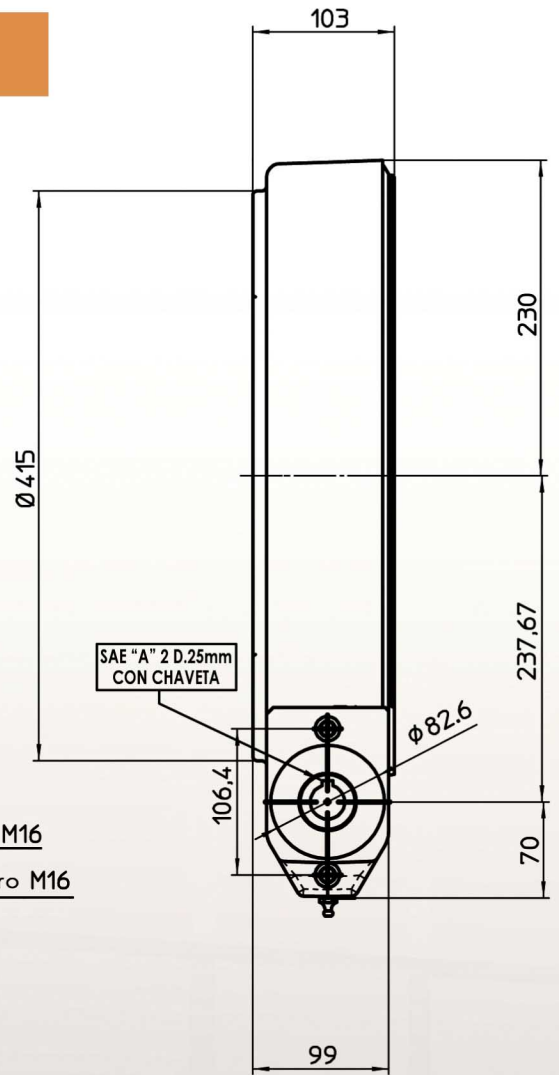
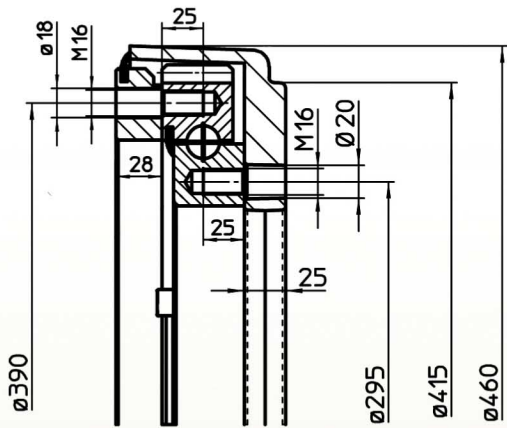

CB-E-256

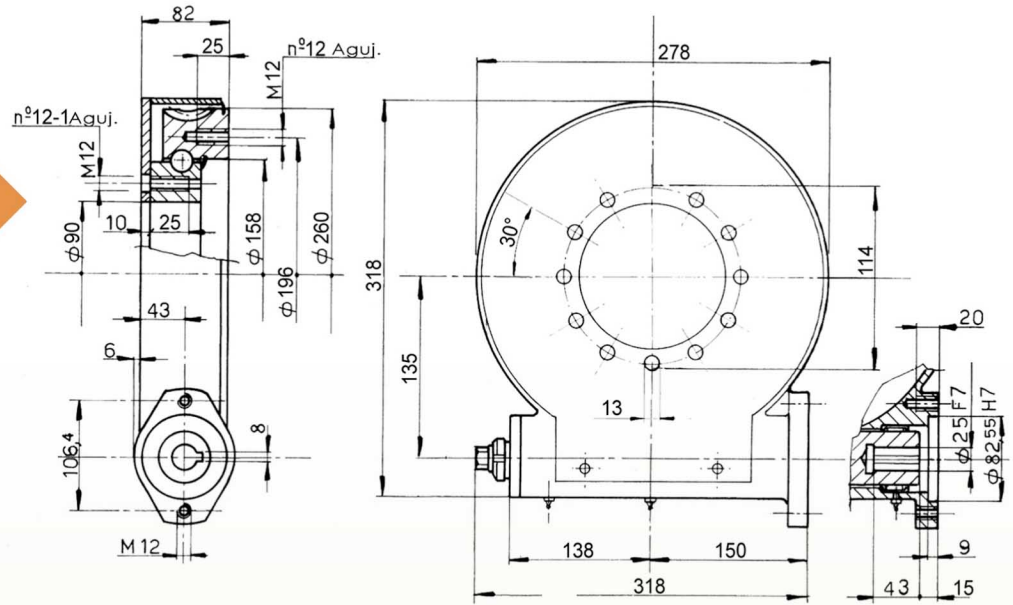

CB-E-316

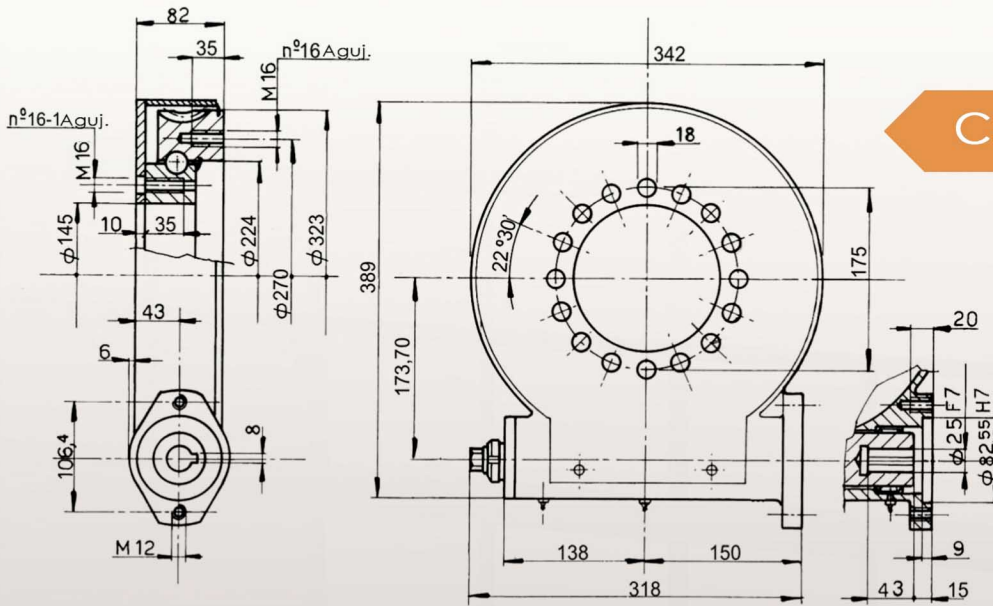

CB-E-527

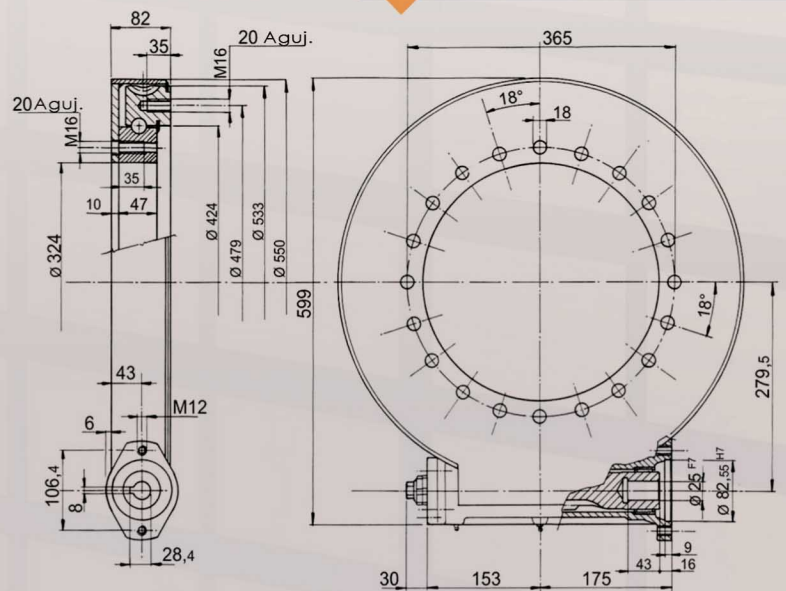

* Disponibles también con doble giro de bolas

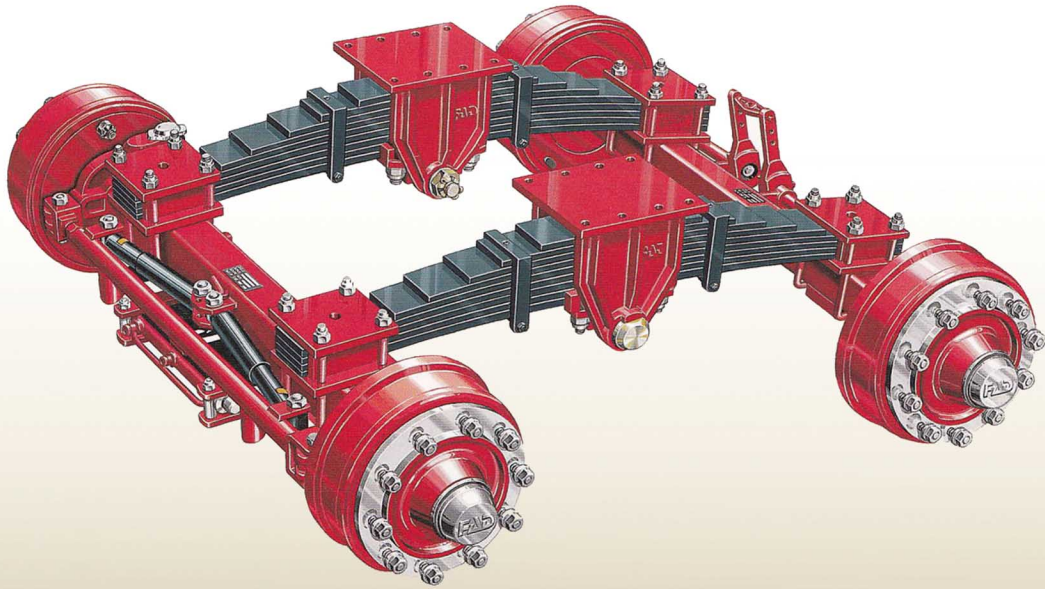

EJES Y SUSPENSIONES

FAD ASSALI s.p.a.

Desde 1954 a vuestro servicio

AGRI STEFEN

De la experiencia en la carretera
a la práctica en el campo



LEONESSA
GROUP

LEONESSA

LEONESSA
NORTH AMERICA

FAD ASSALI

AGRI
STEFEN

LEONESSA brevini
TARGHIERO SUDIO SUDIO 1975



ISO 14000



OHSAS 18001



ISO 9001



TECNOLOGÍA, INVESTIGACIÓN Y DESARROLLO

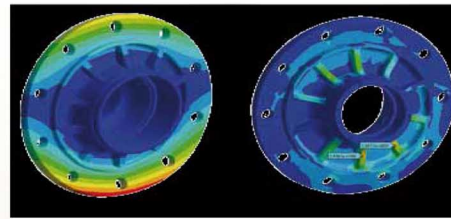
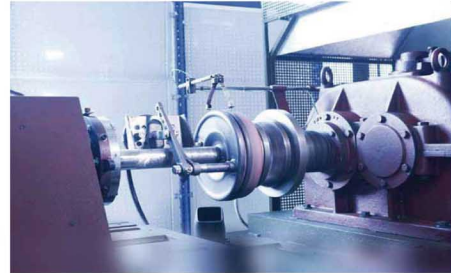

LAMINACION Y FORJA PROPIA



PROCESOS

Forja buje



Mecanizado buje



Mecanizado palanquilla



Soldadura ejes y direccionales



Montaje ejes



EJES SIN FRENO

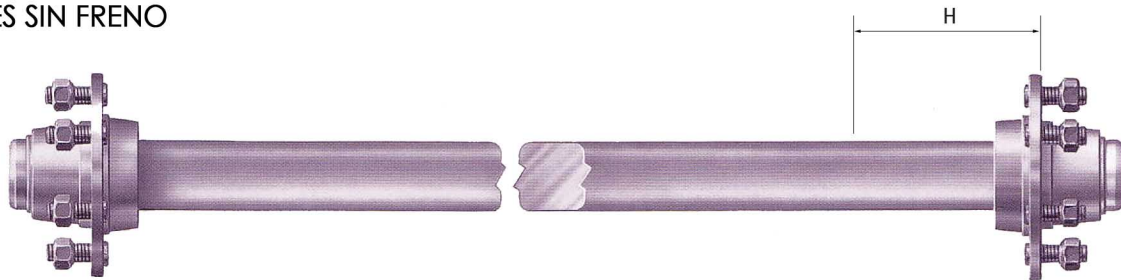

EJES SIN FRENO TIPO	RODAMIENTOS	H	GARGA A (KM) A 40 KM/H			PESO
EAS- 3025- 5812	30204/30205	135	850	700	600	10
EAS- 3525- 5812						13,4
EAS- 4030- 9316	30205/30206	205	1500	1300	1050	18,1
EAS- 4540- 9316						23,8
EAS- 5045- 9316	30206/30209	250	2700	2200	2000	30,5
EAS 5045 - 16018						38
EAS 6055 - 16018	30208/30211	300	4400	3800	3400	60
EAS 7055 - 16018						72,40
EAS 7065 - 16018	30210/30213		6000	5300	4500	77,80

Consultar pisas y otros tramos y medidas

SEMIEJES SIN FRENO

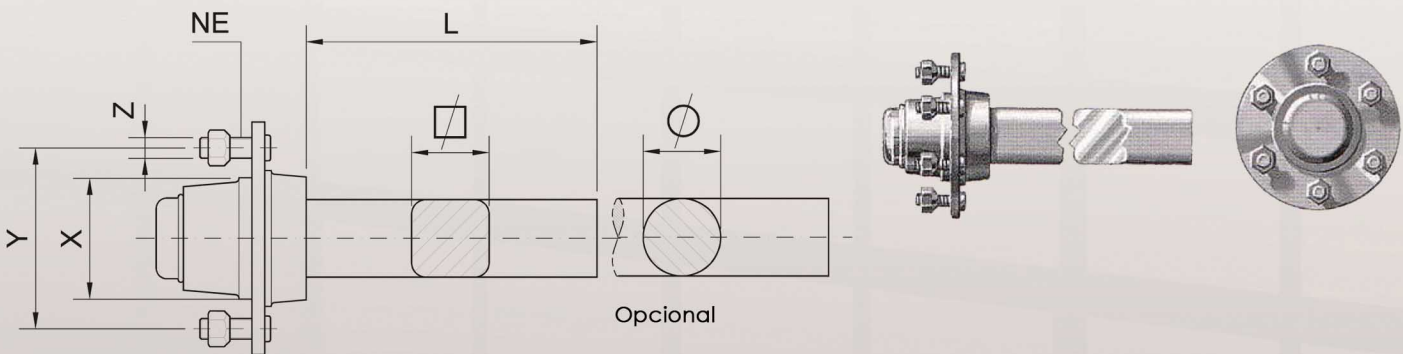

REF.	ATAQUE	RODAMIENTOS	L	CARGA A 40 Km/h			PESO
SES301 - 3025 - 05812	58 x 98 / 4-M12	30204/30205	200	425	350	300	3,4
SES351 - 3525 - 05812							3,8
SES401 - 4030 - 09316	93 x 140 / 5-M16	30205/30206	200	750	650	525	6,4
SES451 - 4540 - 09316		30206/30208					8,4
SES501 - 5045 - 09316		30206/30209					9,4
SES601- 6055 - 016018	160 x 205/ 6-M18	30208/30211	200	2200	1900	1700	17
SES701- 7065 - 016018		30210/30213					21,4

SEMIEJES PIVOTANTES

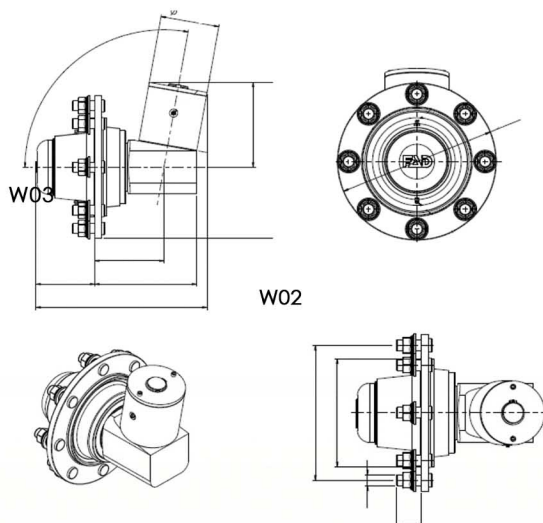
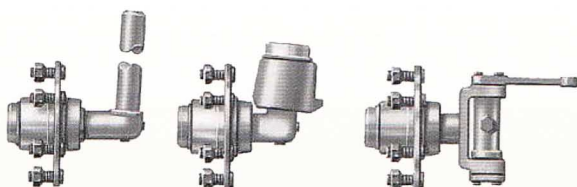
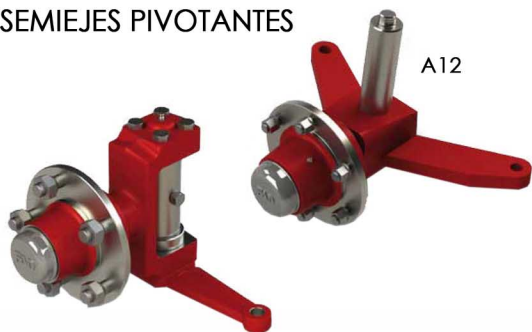

Tipo		
	25 km/h	40 km/h
W01	350	300
W02	2000	1800
W02	1800	1600
W02	1500	1300
W03	1500	1300
A12	-	3500
A12	-	8200

CABEZAS DE TRAILLA

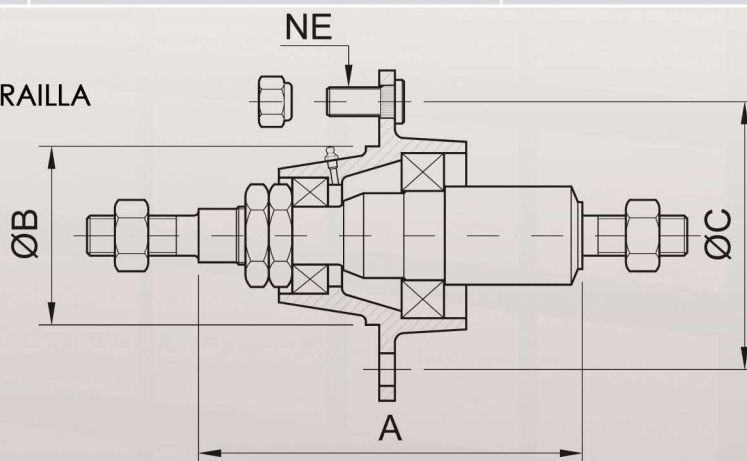

REF.	A	B	C	E	CARGA	PESO
TR-45.40.093.16	170	93	140	16	1.250	5,5
TR-50.45.093.16	200	93	140	16	1.650	7
TR-50.45.093.16	250	93	140	16	1.650	8
TR-50.45.160.20	250	160	205	20	1.650	9,5
TR-60.55.160.20	250	160	205	20	2.400	10
TR-70.55.160.20	250	160	205	20	2.400	11
TR-70.65.160.20	280	160	205	20	3.000	13
TR-80.65.160.20	280	160	205	20	3.000	15
TR-90.75.160.20	300	160	205	20	4.250	20

EJES RECTOS FRENO "MONOBLOK"

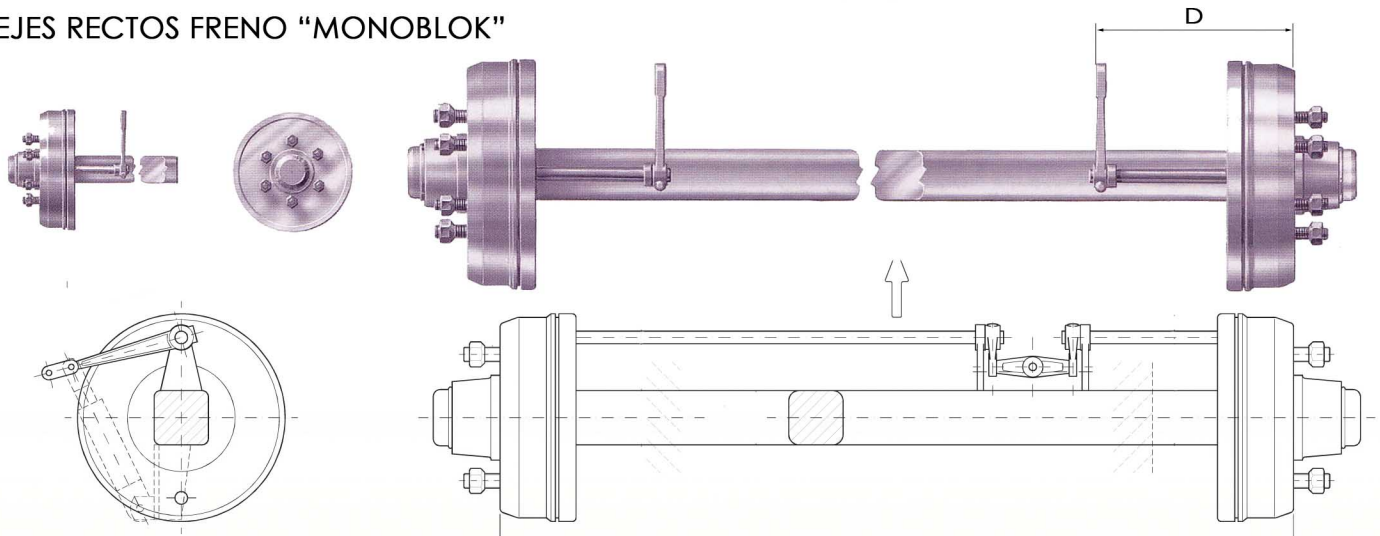

COD	DESCRIPCIÓN	REF. ORIGEN	POS LEVA	RODAMIENTO/ MANGA	CAPACIDAD CARGA 40 KM/H			PESO
	<input checked="" type="checkbox"/> MNG FRENO PISA ATQ.		D o Balancín**					
EAF303	EM 30.25 140X030 1000 58/12	F30A007	D243	30204-30205 M25	850	700	600	15
EAF454	EM 45.40 200X040 1050 93/16	F45B032	D300 D400	30206-30208 M40	2200	1900	1500	32
EAF452	EM 45.40 200X040 1100 93/16	F45B019	D300	30206-30208 M40	2200	1900	1500	32
EAF451	EM 45.40 200X040 1300 93/16	F45B006	D400	30206-30208 M40	2200	1900	1500	49
EAF515	EM 50.45 200X040 1100 93/16	F50B085	D145	30206-30209 M45	2700	2200	2000	39
EAF504	EM 50.45 250X040 1200 160/18	F50C031	D400	30206-30209 M45	2700	2200	2000	43
EAF618	EM 60.50 250X040 1500 160/18	F60C172	D170	30207-30210 M50	3.800	3.400	3.000	80
EAF612	EM 60.55 300X060 1600 160/18	F60W307	BL DD135	30208-30211 M55	4.400	3.800	3.400	95
EAF604	EM 60.55 300X060 1700 160/18	F60W303	BL DD185	30208-30211 M55	4.400	3.800	3.400	98
EAF609-1	EM 60.55 300X060 1700 160/18	F60W3850N4	D170	30208-30211 M55	4.400	3.800	3.400	103
EAF712	EM 70.55 300X060 1900 160/18	F70W642	BL DD235	30208-30211 M55	4.600	4.000	3.600	125
EAF701	EM 70.65 300X060 1400 160/18	F70W080	D425	30210-30213 M65	6.000	5.300	4.500	111
EAF711	EM 70.65 300X060 1500 160/18	F70W044	D425	30210-30213 M65	6.000	5.300	4.500	102
EAF713	EM 70.65 300X060 1500 160/18	F70W368	D490	30210-30213 M65	6.000	5.300	4.500	116
EAF704	EM 70.65 300X060 1600 160/18	F70W504	BL DD135	30210-30213 M65	6.000	5.300	4.500	119
EAF703	EM 70.65 300X060 1700 160/18	F70W498	BL DD182	30210-30213 M65	6.000	5.300	4.500	122
EAF706	EM 70.65 300X060 1800 160/18	F70W510	BL DD235	30210-30213 M65	6.000	5.300	4.500	126
EAF716	EM 70.65 300X060 1800 160/18	F70W571	BC	30210-30213 M65	6.000	5.300	4.500	126
EAF717	EM 70.65 300X060 1900 160/18	F70W582	BC	30210-30213 M65	6.000	5.300	4.500	130
EAF708	EM 70.65 300X060 2100 160/18	F70W560	BL DD435	30210-30213 M65	6.000	5.300	4.500	137
EAF722	EM 70.65 300X060 2100 220/20	F70W704	D840	32210-32213 M65	6.000	5.300	4.500	135
EAF705	EM 70.65 300X060 2200 160/18	F70W508	BL DD435	30210-30213 M65	6.000	5.300	4.500	141
EAF709	EM 70.65 300X060 2250 160/18	F70W507	BL DD460	30210-30213 M65	6.000	5.300	4.500	143
EAF801	EM 80.65 300X060 1600 160/20	F80W01502	D515	30210-30213 M65	6.000	5.300	4.500	139
EAF811	EM 80.65 300X060 1700 160/18	F80W231	BL DD182	30210-30213 M65	6.000	5.300	4.500	143
EAF802	EM 80.65 300X060 1800 160/18	F80W390	BL DD235	30210-30213 M65	6.000	5.300	4.500	148
EAF818	EM 80.65 300X060 1900 160/18	F80W406	BL DD235	30210-30213 M65	6.000	5.300	4.500	152
EAF820	EM 80.65 300X060 1900 160/18	F80W442	D650	30210-30213 M65	6.000	5.300	4.500	152
EAF821	EM 80.75 300X060 1500 160/18	F80W372	D425	32211-32215 M75	8.000	7.200	6.200	140
EAF803	EM 80.75 300X060 1600 160/18	F80W370	D425	32211-32215 M75	8.000	7.200	6.200	143
EAF804	EM 80.75 300X060 1700 160/20	F80W235	BL DD182	32211-32215 M75	8.000	7.200	6.200	149
EAF806	EM 80.75 300X060 1800 160/20	F80W04201	D655	32211-32215 M75	8.000	7.200	6.200	152
EAF807	EM 80.75 300X060 1800 160/20	F80W234	BL DD235	32211-32215 M75	8.000	7.200	6.200	154
EAF817	EM 80.75 300X060 1900 160/20	F80W326	BL DD335 GEM	32211-32215 M75	8.000	7.200	6.200	159
EAF808	EM 80.75 300X060 2000 160/20	F80W281	BL DD335	32211-32215 M75	8.000	7.200	6.200	165
EAF823	EM 80.75 300X060 2100 160/20	F80W429	BL DD390	32211-32215 M75	8.000	7.200	6.200	165
EAF810	EM 80.75 300X060 2250 160/20	F80W310	BL DD435	32211-32215 M75	8.000	7.200	6.200	175
EAF902	EM 90.75 300X060 1700 160/20	F90W033	BL DD182	32211-32215 M75	9.000	8.000	7.000	176
EAF903	EM 90.75 300X060 1800 160/20	F90W074	D655	32211-32215 M75	9.000	8.000	7.000	182
EAF912	EM 90.75 300X060 1900 160/20	F90W053	D600	32211-32215 M75	9.000	8.000	7.000	188
EAF915	EM 90.75 300X060 2000 160/20	F90W078	D650	32211-32215 M75	9.000	8.000	7.000	195





** Balancín Lateral:

DDXXX Desplazado del centro a la derecha xxx mm.

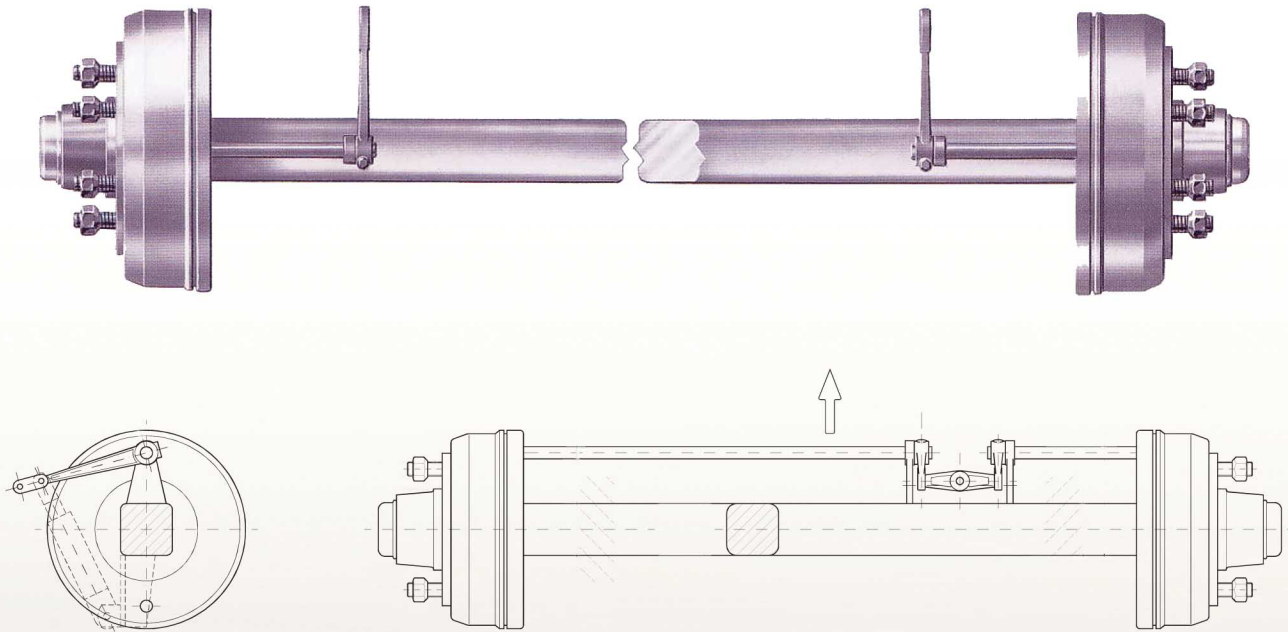
BC Balancín central

EJES RECTOS FRENO TAMBOR FUNDICIÓN



COD	DESCRIPCIÓN	REF. ORIGEN	POS LEVA	RODAMIENTO/ MANGA	CAPACIDAD CARGA 40 KM/H			PESO
	 MNG FRENO PISA ATQ.		D o Balancín**					
EAF805	EF 80.75 300X060 1800 220/20	F80E1421	BL DD235	32211-32215 M75	8.000	7.200	6.200	170
EAF814	EF 80.75 350X060 1800 220/20	F80G0031	BC	32211-32215 M75	8.000	7.200	6.200	160
EAF824	EF 80.75 300X060 2100 220/20	F80E209	D840	32211-32215 M75	8.000	7.200	6.200	162
EAF914	EF 90.75 300X060 1800 220/20	F90E033	D600	32211-32215 M75	9.000	8.000	7.000	191
EAF906	EF 90.75 350X060 1800 220/20	F90G108	BL DD235	32211-32215 M75	9.000	8.000	7.000	206
EAF913	EF 90.75 350X060 1800 220/20	F90G062	D530	32211-32215 M75	9.000	8.000	7.000	206
EAF907	EF 90.75 350X060 1900 220/20	F90G107	BL DD285	32211-32215 M75	9.000	8.000	7.000	212
EAF908	EF 90.75 350X060 1900 220/20	F90G157	D810	32211-32215 M75	9.000	8.000	7.000	212
EAF909	EF 90.75 350X060 2000 220/20	F90G126	BL DD335	32211-32215 M75	9.000	8.000	7.000	282
EAF901	EF 90.80 350X060 1800 220/20	F90G203	BC	32212-32216 M80	10.000	9.000	8.000	219
EAF910	EF 90.80 350X060 1900 220/20	F90G1221	BL DD285	32213-32216 M80	10.000	9.000	8.000	232
EAF911	EF 90.80 350X060 2000 220/20	F90G0242	BC	32213-32216 M80	10.000	9.000	8.000	238
EAF103	EF 100.80 350X060 1800 220/20	F10G0481	D600	32212-32216 M80	12.000	11.000	10.000	250
EAF105	EF 100.80 350X060 1900 220/20	F10G037	D600	32212-32216 M80	11.000	10.000	8.500	247
EAF101	EF 100.85 350X060 2000 220/20	F10G00301	D720	32212-32216 M80	11.000	10.000	8.500	256
EAF108	EF 100.80 400X080 1900 280/22	F10L144	D700 LR	32213-32217 M85	12.000	11.000	10.000	264
EAF1011	EF 100.85 400X080 1650 280/22	F10L122	D730	32214-32217 M85	12.000	11.000	10.000	245
EAF104	EF 100.85 400X080 1700 220/20	F10L399	D650	32214-32217 M85	12.000	11.000	10.000	250
EAF109	EF 100.85 400X080 1900 220/20	F10L362	D730	32214-32217 M85	12.000	11.000	10.000	268
EAF1010	EF 100.85 400X080 1900 280/22	F10L2771	BL DD285	32214-32217 M85	12.000	11.000	10.000	281
EAF1014	EF 100.85 400X080 2000 220/20	F10L2251	BL DD335	32213-32217 M85	12.000	11.000	10.000	270
EAF1012	EF 100.85 400X080 2000 280/22	F10L304	BC	32213-32217 M85	12.000	11.000	10.000	272
EAF107	EF 100.85 400X080 2000 280/22	F10L209	D560	32213-32217 M85	12.000	11.000	10.000	271
EAF1013	EF 100.85 400X120 2000 280/22	F10N0391	D805	32213-32217 M85	12.000	11.000	10.000	307
EAF142	EF 140.105 400X120 2000 280/22	T114C1M002S	D805 LR	32218-32221 M105	13.000	12.500	11.900	350

** Balancín Lateral:
DDXXX Desplazado del centro a la derecha xxx mm.
BC Balancín central
LR: Leva Regulable

EJES AUTODIRECCIONALES Y COMANDADOS

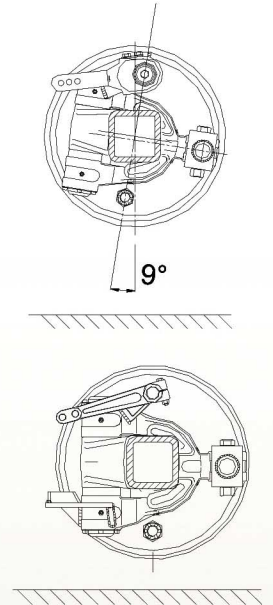
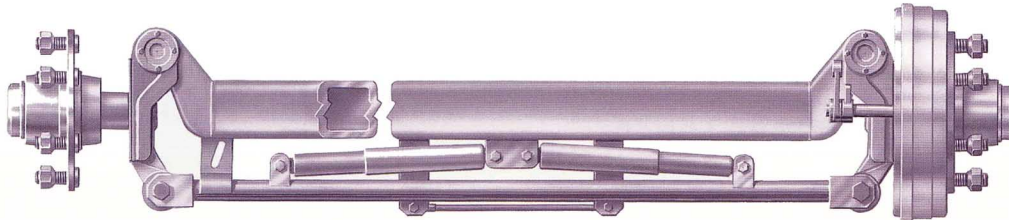

COD	DESCRIPCIÓN	REF. ORIGEN	POS LEVA	RODAMIENTO/ MANGA	CAPACIDAD CARGA 40 KM/H	PESO
	<input type="checkbox"/> MNG FRENO PISA ATQ.		D o Balancín**			
EAF112	ED 110.75 350X060 1800 220/20	H11A2G017		32211-32215 M75	6.200	308
EAF111	ED 110.75 350X060 1900 220/20	H11A2G024		32211-32215 M75	6.200	311
EAF118	ED 110.80 350X060 1800 220/20	H11A1G008		32212-32216 M80	7.000	315
EAF113	ED 110.80 350X060 1900 220/20	H11A1G006		32212-32216 M80	7.000	324
EAF114	ED 110.80 350X060 2000 220/20	H11A1G011		32212-32216 M80	7.000	328
EAF121	ED 120.80 400X080 2000 220/20	H12A1L007		32212-32216 M80	7.500	366
EAF126	ED 120.85 400X080 1900 220/20	H12B1L022		32213-32217 M85	9.000	330
EAF122	ED 120.85 400X080 2000 280/22	H12B4L015		32214-32217 M85	9.000	412
EAF123	ED 120.85 400X120 2000 280/22	H12B1N045	LR	32213-32217 M85	9.000	426
EAF131	ED 130.85 400X120 2000 280/22	H13C3N008	LR	32214-32217 M85	10.000	457
EAF124	EDC 120.80 400X080 1900 220/20	HA2A1L009	COMANDADO	32212-32216 M80	7.500	376
EAF125	EDC 120.85 400X080 2000 280/22	HA2B4L001	COMANDADO	32214-32217 M85	9.500	426
EAF141	EDC140.105 400X120 2000 280/22	VA4C1M012S	COMANDADO LR	32218-32221 M105	14.600	640

EJE COMANDADO

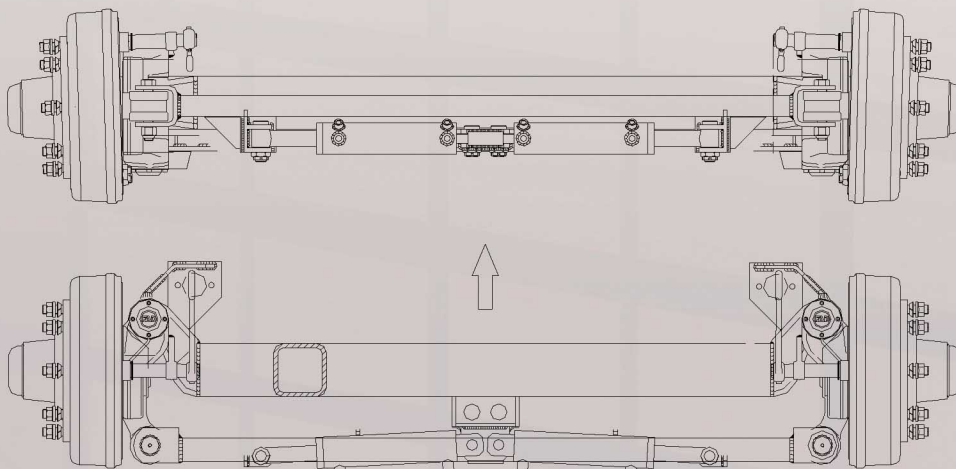



DE LA EXPERIENCIA DE LA CARRETERA
A LA PRÁCTICA EN EL CAMPO

AGRISTEFEN transfiere la importante experiencia adquirida en la producción de ejes industriales al sector agrícola.

La continua modernización de los medios utilizados en la agricultura, que está adquiriendo un nivel tecnológico comparable al industrial ha hecho que AGRISTEFEN ponga a disposición de este sector su experiencia tecnológica.

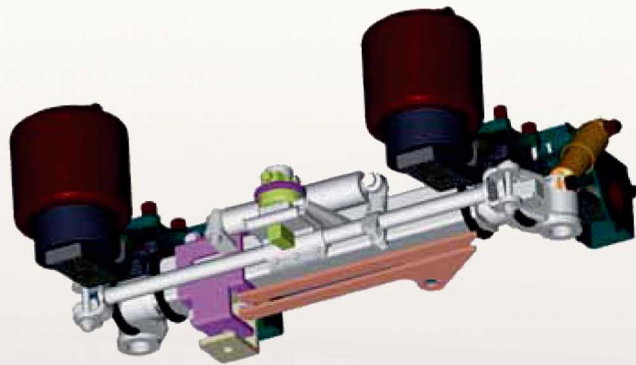

AGRISTEFEN proyecta y desarrolla en colaboración con los clientes sistemas tandem y tridem compuestos de ejes y suspensiones.

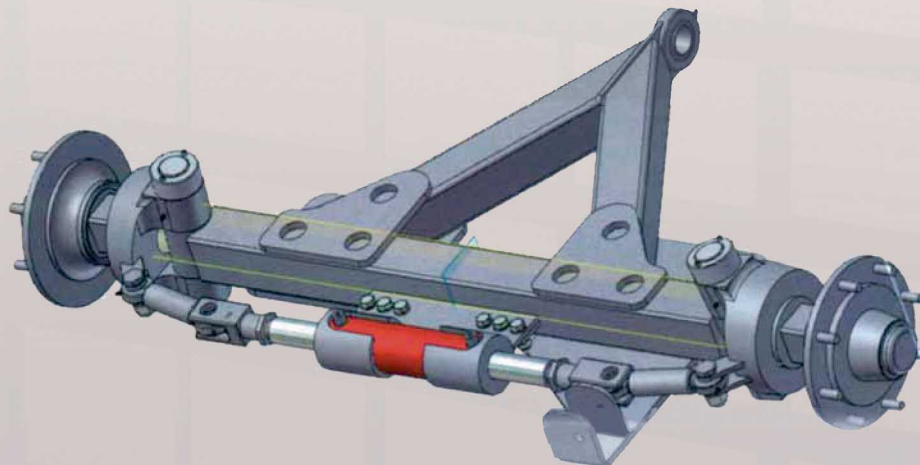

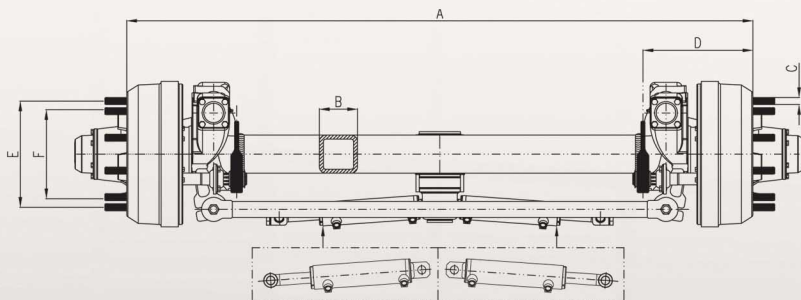
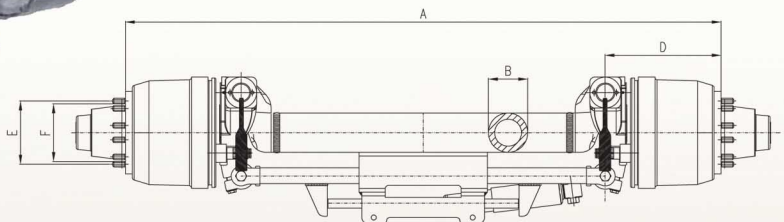
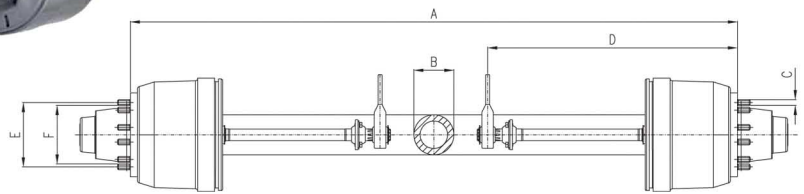

Eje tipo	TAMBOR	capacidad ⁰ (TNS)	tubo cuerpo	levas	ataque
FIJO 300x135 DD	INT	8-10	C90-C100	694	8/220/275 Y 10/176/225
AUTODIRECCIONAL 300x135 DD	INT	8-10	C90-C100	345	8/220/275 Y 10/176/225
FIJO 310x190 AA	INT	10-12	R127	519	10/176/225
AUTODIRECCIONAL 310x190 AA	INT	10-12	R127	375	10/176/225
FIJO 400X80 TT	INT	8-10	R127 -C120-130	742	8/220/275 Y 10/281/335
AUTODIRECCIONAL 400X80 TT	INT	8-10	R127 -C120-130	305	8/220/275 Y 10/281/335
SE FIJO 400X80 TT	INT	4-5	CM90-100 Y C120	550	8/220/275 Y 10/281/335
SE AUTODIRECCIONAL 400X80 TT	INT	4-5	R127-C90-100-110-120-130	330	8/220/275 Y 10/281/335
DIRECCIONAL COMANDADO 400X80 TT	INT	810	R127 -C120-130	305	8/220/275 Y 10/281/335
FIJO 406X120 KZ	EXT	12-16	R127-C130-140-150	720	10/281/335
AUTODIRECCIONAL 406X120 KZ	EXT	12-16	R127-C130-140-150	340	10/281/335
FIJO 406X120 KK	EXT	10-13	R127-C120-130-140-150	725	10/281/335
AUTODIRECCIONAL 406X120 KK	EXT	10-13	R127-C120-130-140-150	346	10/281/335
DIRECCIONAL COMANDADO 406X120 KK *	EXT	10-13	R127-C120-130-140-150	346	10/281/335
DIRECCIONAL COMANDADO 406X120 KK**	EXT	8-10	R127-C120-130-140-150	346	10/281/335
FIJO 420X180 QQ	EXT	10-13	R127-C120-130-140-150	763	10/281/335
AUTODIRECCIONAL 420X180 QQ	EXT	10-13	R127-C120-130-140-150	385	10/281/335
FIJO 420X180 QZ	INT	12-16	R127-C130-140-150	720	10/281/335
AUTODIRECCIONAL 420X180 QZ	INT	12-16	R127-C130-140-150	410	10/281/335

Disponible versión rueda simple o gemela
 ABS corrector de dirección y leva autoregistrable opcional
 Certificado TÜV

ACCESORIOS EJES

LEVAS DE FRENO FIJA Y REGISTRABLE

	FRENO	140x30	200Ax40	250Ax40	250x40	300Ax60	300x60	300x90	350x60	300x135	400x80	400x120	420x180			
LEVA FIJA	D	140	110	110	150	150	210	150	210	180	180	180	180	REG	REG	1*
	H		30	30	30	30	30	30	30	30	30	30	30	REG	REG	

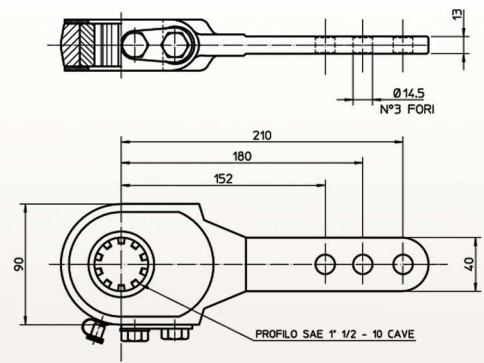
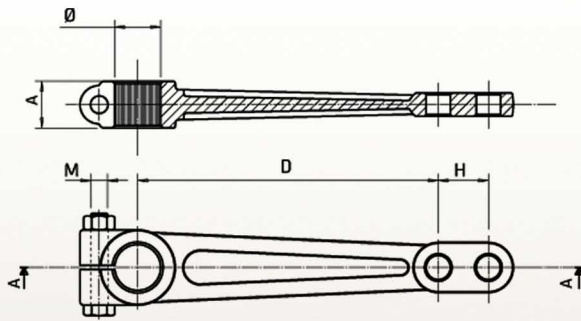

LEVA AUTOREGISTRABLE

	L	L1	L2	L3	L4	L5	S	C	X
LR	120	135	150	165	180	260	45	320	13

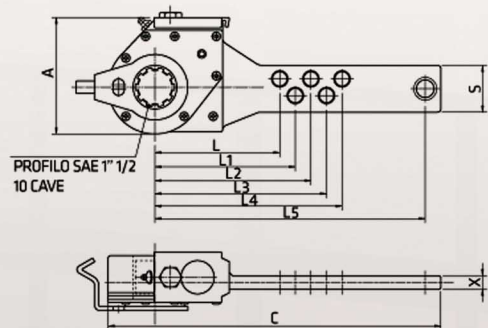

LR

CILINDROS DE FRENO

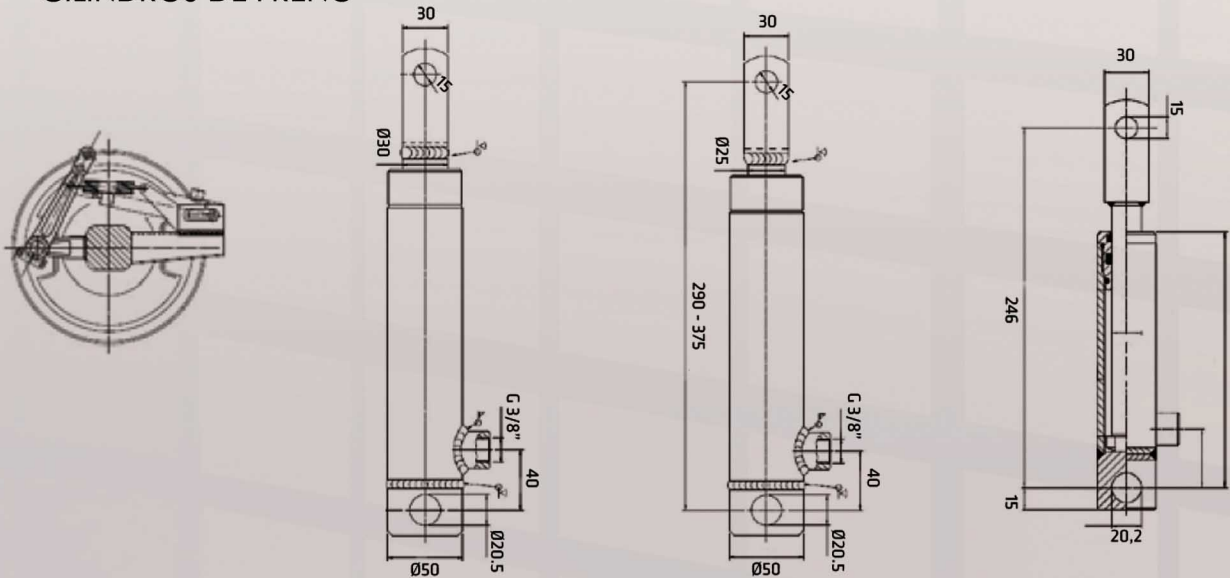

ACCESORIOS EJES

SOPORTE FRENO DE AIRE

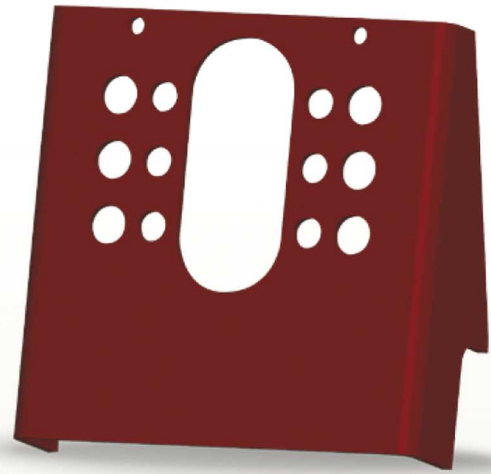
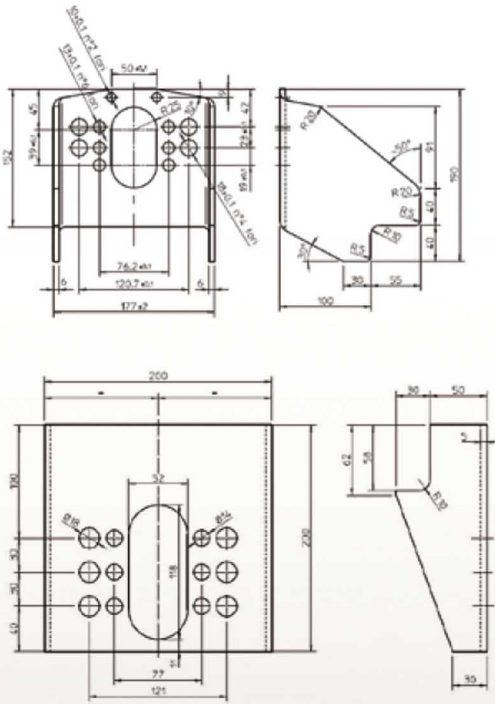

ADAPTADOR PARA CILINDRO EN SOPORTE DE FRENO DE AIRE

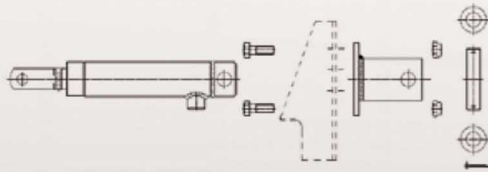

CONECTOR DIRECCIÓN

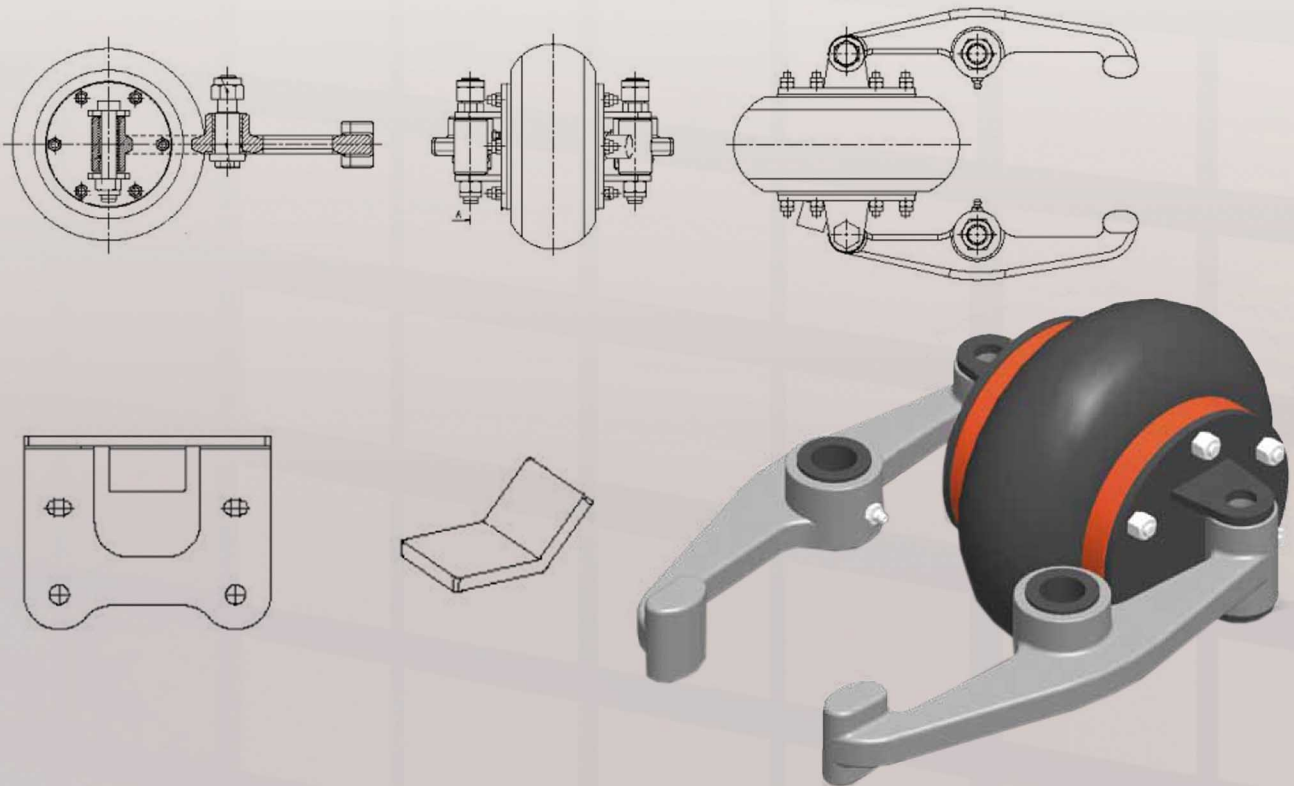

SUSENSIONES MECÁNICAS

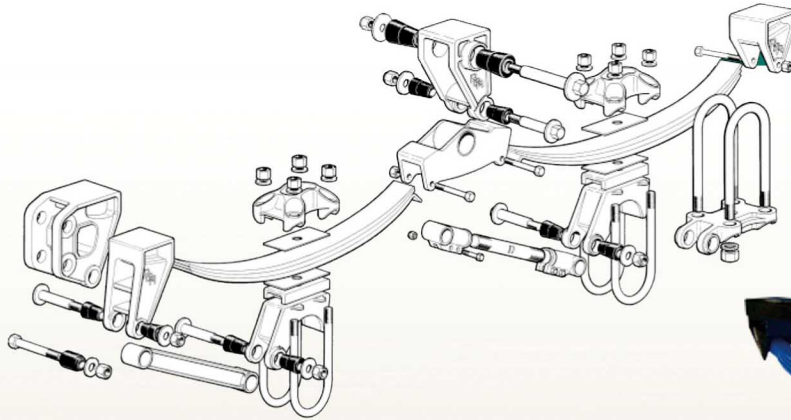
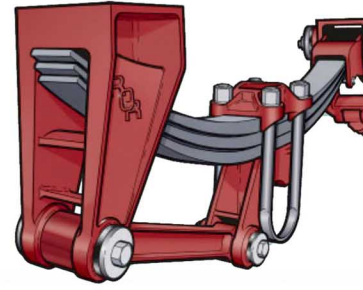

SUSENSIONES SIN TIRANTES

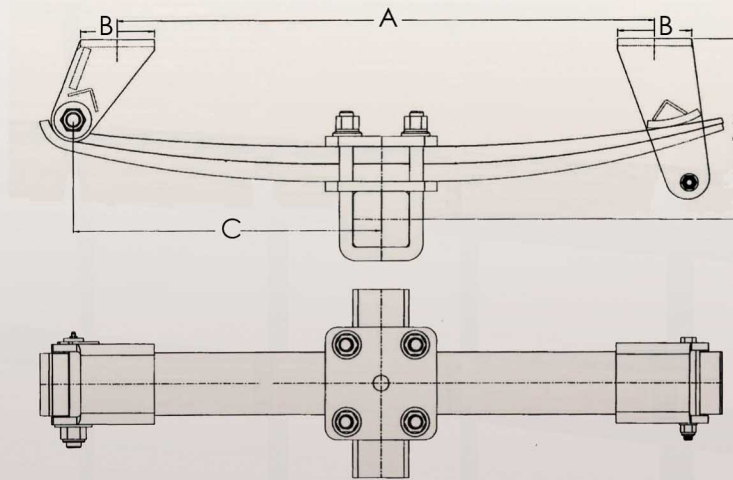

	A	B	C	EJES	BALLESTA	D sin carga	D1 carga nominal
SUS 6 TNS.	665	100	300	70X70	80x20	285	267
SUS 8 TNS.	870	120	500	90X90	100x24	341	317
SUS 10 TNS.	870	120	500	100X100	100x28	346	322

SUSENSIONES MECÁNICAS

■ SUSENSIONES CON TIRANTES PARA VEHÍCULOS DE 1, 2 Y 3 EJES.

■ SUSENSIONES EN FUNDICIÓN

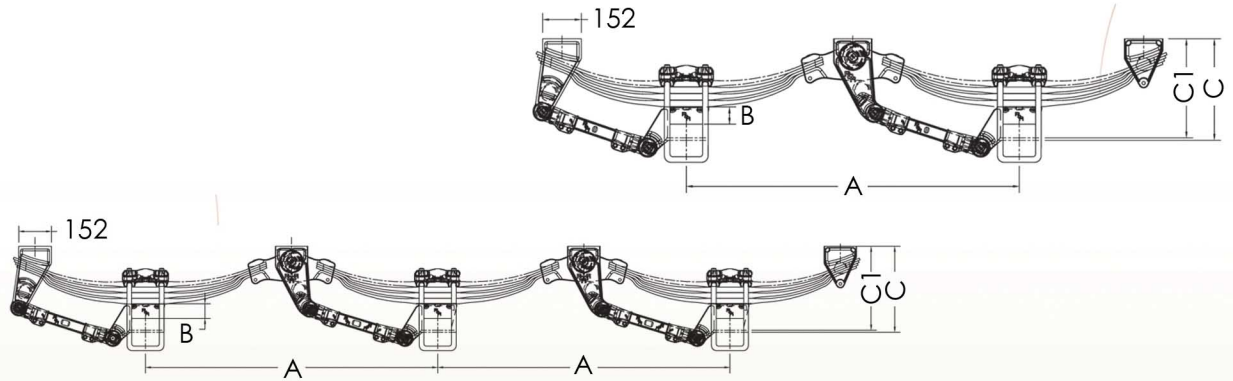

	Capacidad (tns.)	Paso (A)	nº hojas	Altura placa (B)	Eje	Altura sin carga (C1)	Altura con carga (C)
SUS101-1 TANDEM	20	1360	3	26	120	400	353
SUS105 TANDEM	24		4		100	353	306
SUS106 TANDEM	24		4		120	363	316
SUS103-1 TRIDEM	30		3		120	358	311
SUS107 TRIDEM	36		4		100	353	306
SUS108 TRIDEM	36		4		120	363	316

■ SUSENSIONES METÁLICAS

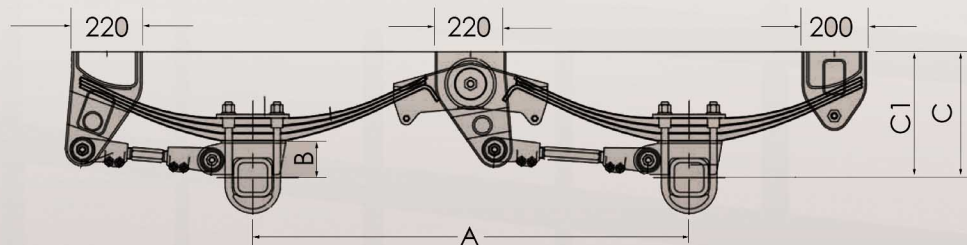

	Capacidad (tns.)	Paso (A)	nº hojas	Altura placa (B)	Eje	Altura sin carga (C1)	Altura con carga (C)
SUS101 TANDEM	20	1360	3	26	120	390	350
SUS102 TANDEM	24		4			410	380
SUS103 TRIDEM	30		3			390	350
SUS104 TRIDEM	36		4			410	380

Disponemos a solicitud en las dos versiones:

Otros pasos (A) de rueda y alturas de placa (B)
 Montaje con eje sobre o debajo de la ballesta
 Para ejes redondos o cuadrados de diferentes medidas
 Ballestas parabólicas y multihojas
 Todos los modelos para vehículos de 1, 2 y 3 ejes

SUSPENSIONES BOGIES

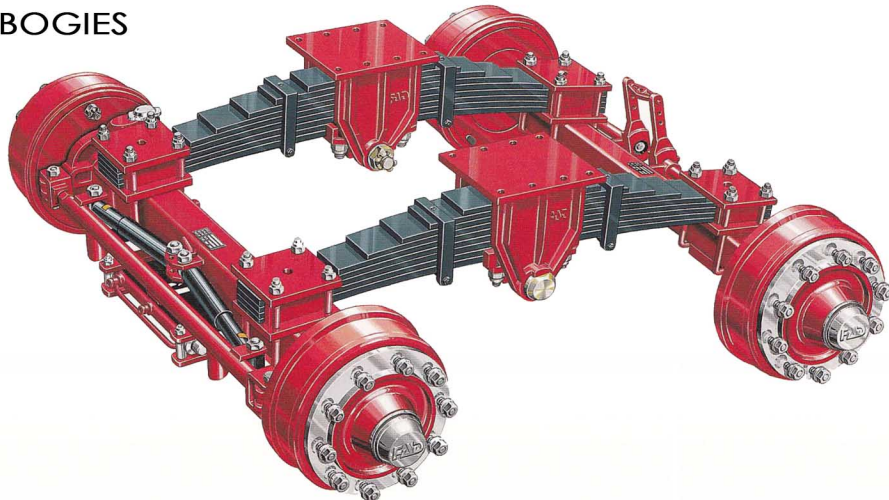

BOGIES TIPO	CAPACIDAD	PASO (A)	BALLESTA	EJES
Tipo 1 8-10 tns.				
	8000	1000	7x100x13	70-80
	10000	1100	6x100x15 6x100x18	
Tipo 2 12-16 tns.				
	12000	1000	5x100x18	80-90-100-110-120
		1200	6x100x18	
	14000	1200	7x100x18	
16000	1370	7x120x18 8x100x18		
Tipo 3 18-21 tns.				
	18000	1370	7x120x20	100-110-120-130-140
		1470	8x120x20	
Tipo 4 21-24 tns.				
	21000	1370	9x120x20	100-110-120-130-140
		1500	9x120x20	
24000	1500	11x120x20		

Disponemos de otras versiones y medidas a solicitud

SUSPENSIONES BOGIES

■ 2 EJES FIJOS O 1 FIJO Y 1 DIRECCIONAL

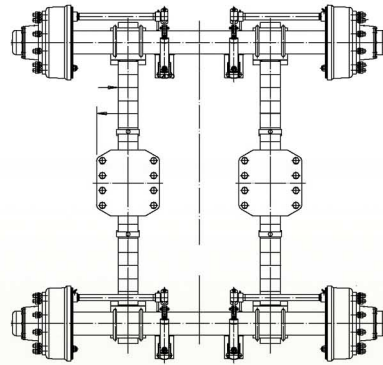
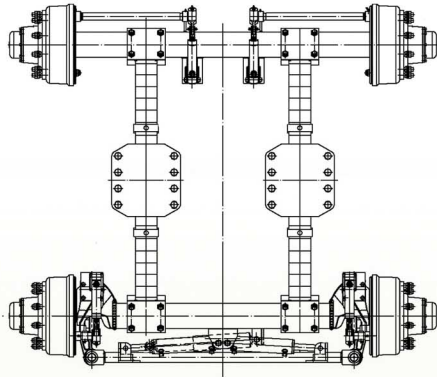

■ EJE SOBRE O DEBAJO DE LA BALLESTA

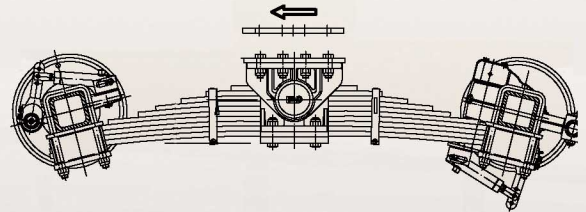
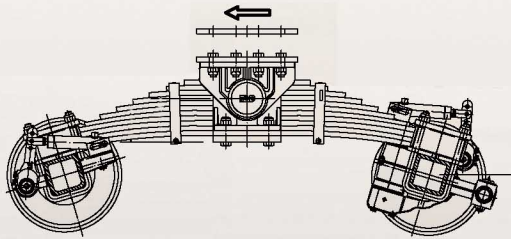

■ OPCIONAL BALLESTA PARÁBOLICA

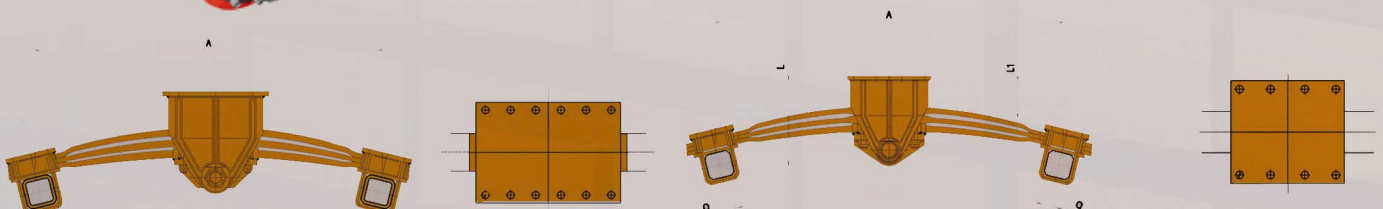
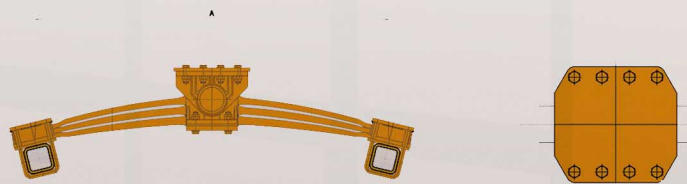

SUSPENSION HIDRÁULICA SIDRA®



- EJE SENCILLO-TANDEM-TRIDEM
- FIJO, AUTODIRECCIONAL Y COMANDADO
- CILINDROS DE SIMPLE Y DOBLE EFECTO
- FÁCIL INSTALACION

TIPO	9000	9000S	12000	14000
Carga max. a 40km/h	9000		12000	14000
Pisa	1950/2000		2000/2150	2060/2100/2500
Altura nominal	355	355	400	450
Freno	400Gx80	400Gx120		412Gx160
Peso mod. Fijo	480	530	620	800
Peso mod. Auto direcc.	580	660	770	920

CARACTERISTICAS Y RENDIMIENTO.

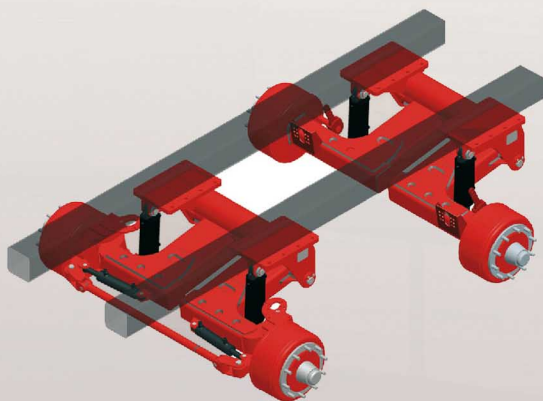

- RUEDAS INDEPENDIENTES
- LA CARGA DESCANSA SOBRE LAS RUEDAS EN TODAS LAS SITUACIONES
- PERFECTA CIRCULACIÓN CON O SIN CARGA
- BLOQUEO DE LOS EJES PARA BASCULACIÓN
- ALIVIA EL EXCESO DE LAS PENDIENTES PRONUNCIADAS

- ANTIVUELCO Y ANTICAÍDA
- ELEVACIÓN DEL EJE DELANTERO
- FRENADO UNIFORME
- BUJE ACERO
- FRENO HOMOLGADO HASTA 105 KM/H SEGÚN LA EEC 71/320
- OPCION SISTEMAS ABS Y RDS

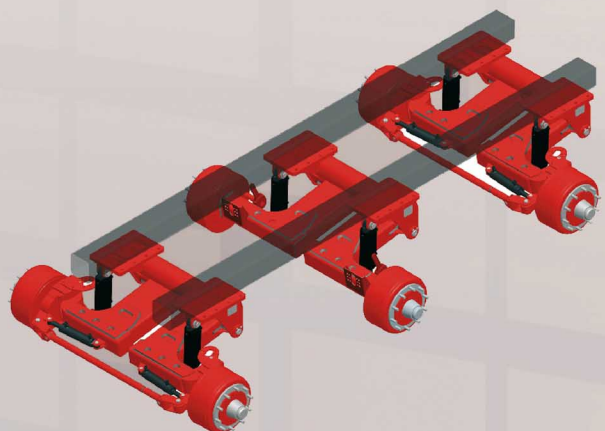

SUSPENSIONES NEUMÁTICAS

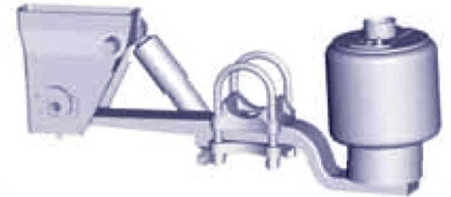
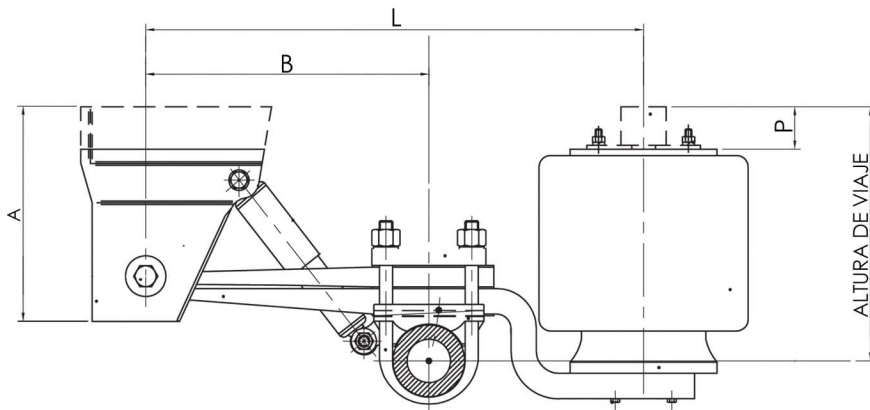

TIPO	A	B	L	P	Altura de Viaje
ROR FLX14000	305	550	1175	6	400
	330			25	425
	355			50	450
ROR FLX12000	305	500	880	6	375
	330			6	400
	355			25	425
	380			50	450
	405			75	475
	430			100	500
	455			125	525
ROR FL9000NB	480	516	895	150	550
	120			0	310
	135			0	325
	160			25	350
	185			50	375

ANCHO BALLESTA : 100 mm

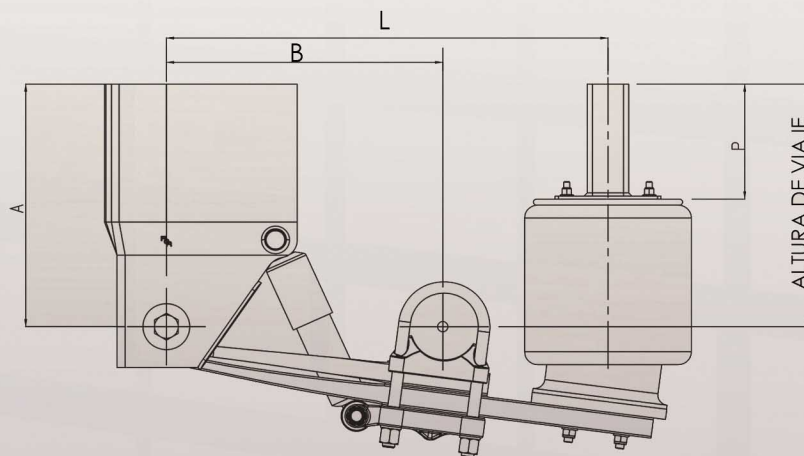

TIPO	A	B	L	P	Altura de Viaje
ROR FLX11000	250		850	6	250
	300			50	300
	350			100	350
	400			150	400
	450			200	450
ROR FP9000	275		905	8	250
	300			25	275
	325			50	300

ANCHO BALLESTA : 100 mm

RECAMBIOS

EJES SIN FRENO

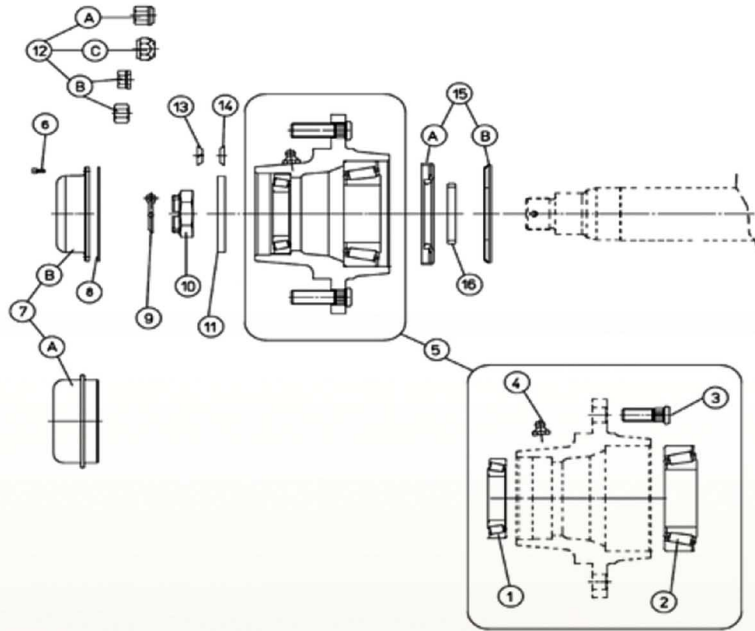

EJES CON FRENO

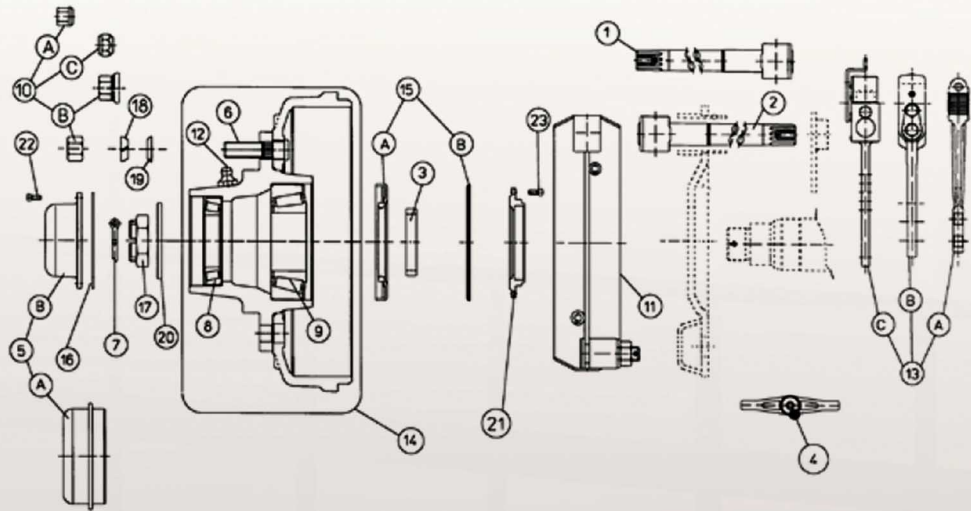

EJE DIRECCIONAL

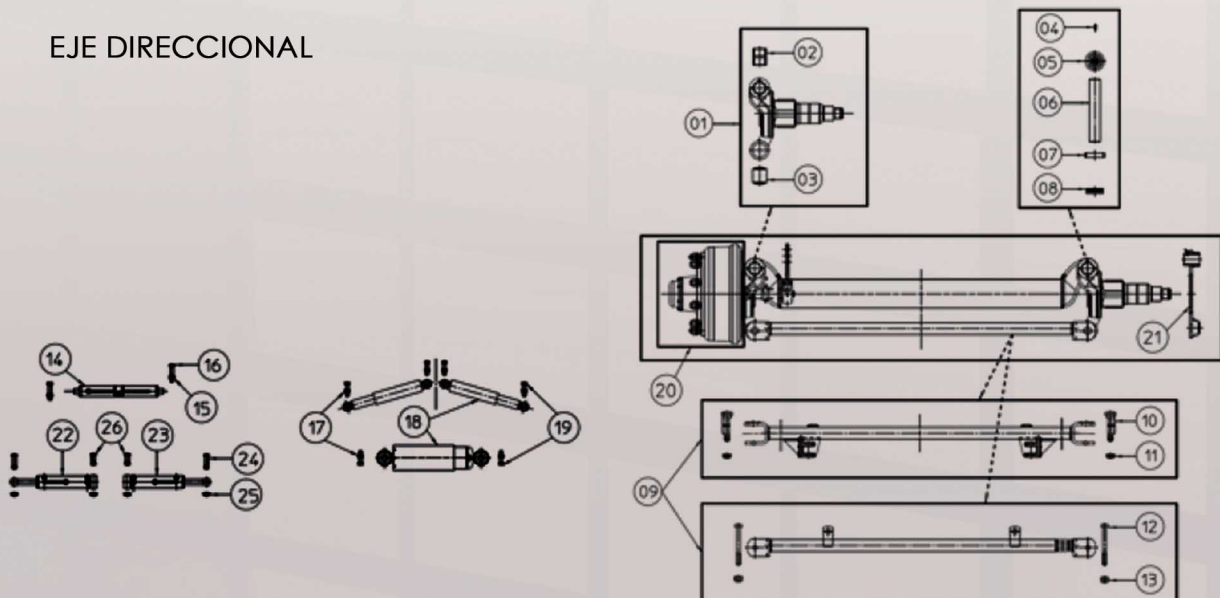

RECAMBIOS SUSPENSIONES

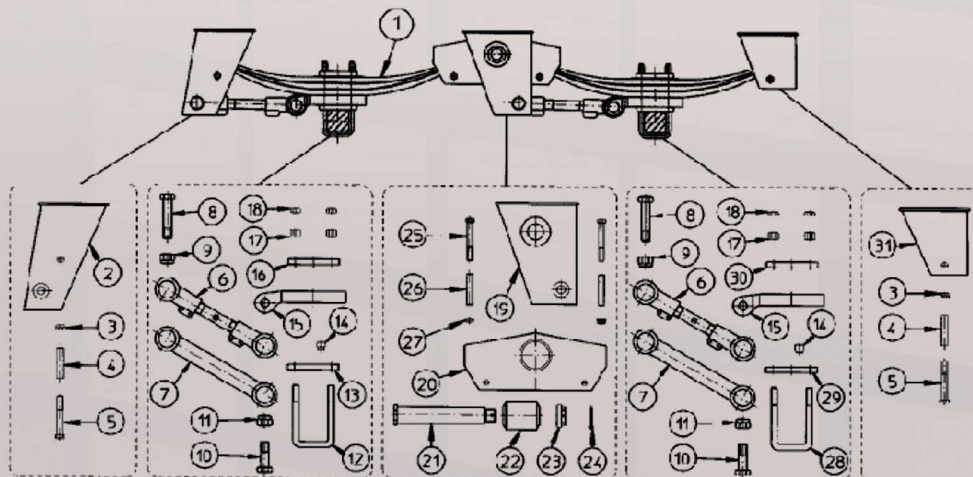
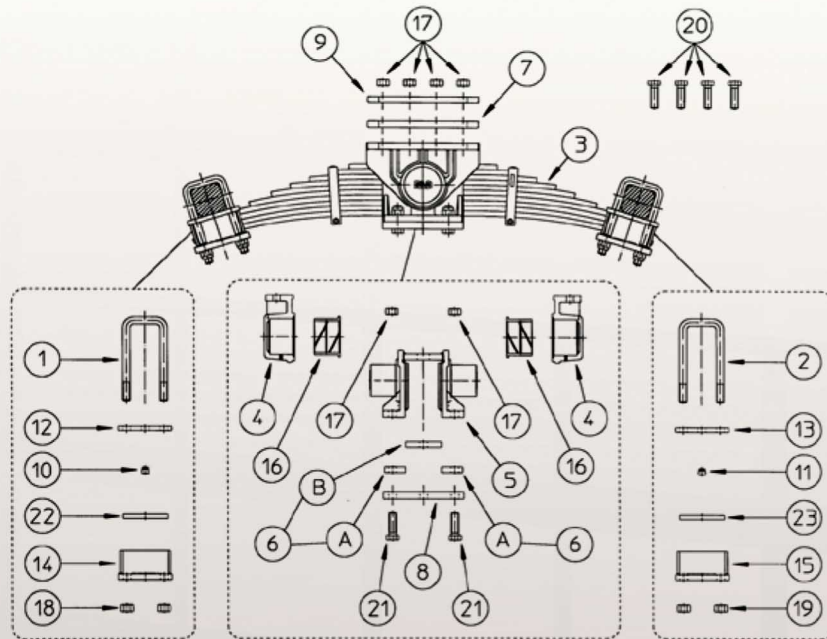
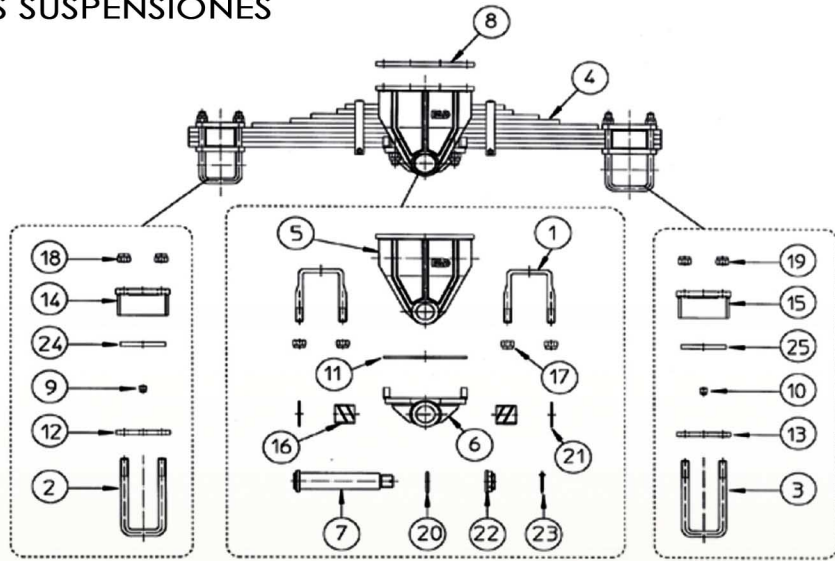



CONJUNTO DE RUEDAS CON NEUMÁTICOS

RUEDAS Y NEUMÁTICOS. REMOLQUES, TURISMOS Y USOS VARIOS.



Código	Neumático	Rueda	Desplaz.	Ataque	Medidas en mm.		Carga/Velocidad*	Presión (bars)	Peso (kgs.)
					ancho	diámetro			
CJT08"005	3.50-8" 4PRC TL	2,50-8"	0	4/ 58,5-98	89	384	6N	2,5	3,5
CJT08"001	4.00-8" 4PR TL	5.50-8"	0	4/ 58,5-98	110	425	62N	4	3,7
CJT08"003	16.5X6,5-8" 4PR TL				165	415	64M	3,1	5,8
CJT10"004	4.50-10" 4PR TL				130	490	69M	7	
CJT10"003	5.00-10" 4PR TL	3.50-10"	0	4/ 58,5-98	145	515	72N	3,5	7,5
CJT10"006	5.00-10" 8PR TL		4				8		
CJT10"002	145-10" 4PR TL	3.50-10"	0		145	485	68M	2,5	7
CJT10"007	20.5X8.0-10" 10PR TL	6.00-10"	0		200	515	96M	6	15
CJT13"002	135/80R - 13" TL	4J-13"	30	4/ 58,5-98	135	546	69N	2,5	10,5
CJT13"003	145/80R - 13" TL	4J-13"			145	562	78N		11
CJT13"004	155/80R - 13" TL	4J-13"			155	578	79N		12
CJT13"005	165/80R - 13" TL	4J-13"			165	594	83T	12,5	
CJT13"006	175/70R - 13" TL	41/2J-13"			175	576	82T	13	
CJT13"007	195/50R - 13" TL	61/2J-13"		5/66.6-112	195	526	104/102N	6,75	-
CJT13"008	195/50R - 13" TL	61/2J-13"		5/94x140	195	526	104/102N	6,75	-
CJT14"003	185/70R - 14" TL	51/2J-14"	30	4/ 58,5-98	185	616	88H	2,5	18
CJT14"005	185R - 14" 8 PR CAR.	5J-14"	0	5/94x140	185	655	102/100Q	4,5	20
CJT14"006	205R - 14" 8 PR CAR	5J-14"		5/94x140	205	686	109/107R		21
CJT15"006	235/75R - 15" TL	6J-15"	30	6/110x139.7NS	235	733	105S		22
CJT16"008	215/80R - 16" TL	5.50F-16"	46	5/115.2x165.1LR	215	750	115/112R		27
CJT16"009	215/80R - 16" TL	6J-16"	30	6/110x139.7NS	215	750	115/112R		29

*Ver tabla Índices de carga y velocidad

RUEDAS Y NEUMÁTICOS PARA REMOLQUES, CISTERNAS, ESPARCIDORES Y USOS VARIOS.

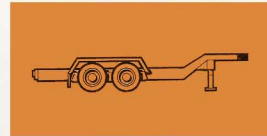
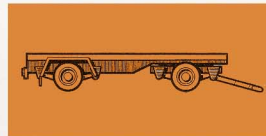
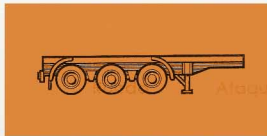

Ø	Neumático**	Rueda	Ataque	Medidas en mm.		Indice Carga/vel.*	Presión (bars)	Peso (kgs.)
				ancho	diámetro			
17,5	215/75 R 17,5	6.75x17,5	6/ 161-205	215	767	135/133J	8	35
	225/75 R 17,5			225	783	129/127M		36
	235/75 R 17,5			235	797	143/141J		37
	245/70 R 17,5			245	813	143/141J		38
19,5	245/70 R 19,5	8.25x19,5	6/ 161-205 y 8/ 221-275	245	839	141/140J	8,5	50
	265/70 R 19,5			265	867	143/141J		60
	285/70 R 19,5			285	880	150/147J		70
	305/70 R 19,5			305	910	148/145M		70
	385/55 R 19,5	11.75x19,5	8/ 221-275	385	920	160J	80	
	435/50 R 19,5	13.00x19,5		435	931	160J	90	
	445/45 R 19,5	11.75x22,5		445	910	160J	90	
	385/55 R 22,5	11.75x22,5		385	996	160K	100	
22,5	385/65 R 22,5	14.00x22.5"	8/ 221-275 y 10/281-335	385	1072	160K	9	110
	445/65 R 22,5			445	1150	168K		120

* Ver tabla de índices de carga y velocidad.

** Disponibles mismas medidas de neumáticos vulcanizados en carcasa de camión.

RUEDAS Y NEUMÁTICOS FLOTACIÓN Y TRACCIÓN



Fig.1



Fig.2



Fig.3



Código	Neumático	Dibujo	Rueda	Desplaz.	Ataque	Medidas en mm.		Índice Carga/vel. *	Presión (bars)	Peso (kgs.)
						ancho	diámetro			
CJT12"002	10/80-12" 10PR	Fig.1	7.00-12"	0	5/ 94-140	260	710	120A8	3	20
CJT15,3"005	10.0/75-15,3" 10PR		9.00-15.3"			270	750	123A8	4	33
CJT15,3"006	10.0/75-15,3" 12PR							126A8	4,75	34
CJT15,3"007	10.0/75-15,3" 14PR		9.00-15,3" REF.			290	850	130A8	5,5	35
CJT15,3"001	10.0/75-15,3" 18PR							143A8	7	39
CJT15,3"002	11.5/80-15,3" 10PR		9.00-15.3"			6/ 161-205	131A8	3,5	36	
CJT15,3"008	11.5/80-15,3" 12PR							134A8	4	37
CJT15,3"004	11.5/80-15,3" 14PR							139A8	4,75	39
CJT15,3"003	11.5/80-15,3" 16PR							142A8	5,5	42
CJT15,5"002	400/60 15.5" 14PR		Fig.2			13.00-15.5"	8/ 221-275	405	875	145A8
CJT15,5"001	400/60 15.5" 14PR	400		875	145A8	3,5		62		
CJT22.5"011	550/60 22,5" 16PR	Fig.3		16.00X22.5"	537	1254		163A8	2,8	110
CJT22.5"012	560/60R 22,5" 161D				564	1244		161D	4	115

*Ver tabla Índices de carga y velocidad

RUEDAS Y NEUMÁTICOS DE USO INDUSTRIAL



Código	Neumático	Rueda	Desplaz.	Ataque	Medidas en mm.		Capacidad de carga a 25 km/h	Presión (bars)	Peso (kgs.)
					ancho	diámetro			
CJT08"008	4.00 - 8" 8PR	3.00D-8"	0	5/ 94-140	112	414	750	8	7,5
CJT08"009	5.00- 8" 10PR	4.33R-8"	AC y AG		135	470	1000	8	9
CJT08"005	18X7 -8" 14PR				173	462	1450	9	20
-	6.00-9" 12PR	4.00E-9"	0	6/ 161-205	160	540	1500	10	17
-	6.50-10" 10PR	5.50F-10"	0		177	588	1500	8	27
CJT10"001	7.00-12" 14PR	5.00S-12"	AC y AG		190	675	2125	9	40
-	7.00-12" 14PR	5.00S-12"		190	675	2125			
-	7.50-15 16PR	6.0S-15"		217	772	3400			
-	8.15-15" 14PR	6,50-15"	AC y AG	215	715	3000	10	50	
-	8.25-15" 14PR			240	835	3300	8	56	



RUEDAS Y MACIZOS SUPERELÁSTICOS.

Código	Macizo	Rueda	Ataque	Medidas en mm.		capacidad carga a 25 km/h	Peso (kgs.)
				ancho	diámetro		
CJT08"010	MCZ 4.00 - 8"	3.00D-8"	5/ 94-140	130	406	730	17
CJT08"011	MCZ 15x41/2 - 8"		4/ 58-98	132	377	800	17
CJT08"012	MCZ 15x41/2 - 8"		132	377	800	17	
CJT08"013	MCZ 5.00 - 8"	4.33R-8"	5/ 94-140	143	458	1090	20
CJT08"007	MCZ 18X7.8 - 8"			187	453	1650	26
CJT09"003	MCZ. 6.00 - 9"			173	629	1450	32
CJT12"012	MCZ 7.00 - 12"	5.00S-12"	6/ 161-205	207	657	2240	40
CJT12"004	MCZ 7.00 - 12"	5.00S-12"		207	657	2240	40
CJT15"005	MCZ 7.50 - 15"	6,50-15"		229	757	3000	-
CJT12"006	MCZ. 8.25 - 15"	6,50-15"	253	819	3540	-	

RUEDAS Y MACIZOS SUPERELÁSTICOS LISOS PARA PLATAFORMAS.

Código	Macizo	Rueda	Ataque	Medidas en mm.		capacidad carga a 25 km/h	Peso (kgs.)
				ancho	diámetro		
CJT08"014	MCZ 12x31/2 - 8"	3.00D-8"	5/ 94-140	100	300	815	10
CJT08"015	MCZ 15x41/2 - 8"		4/ 58-98	132	377	1050	17
CJT08"016	MCZ 15x41/2 - 8"		132	377	1050	17	
CJT08"017	MCZ 17x7 - 8"	4.33R-8"	5/ 94-140	150	430	1400	22

OBRA PÚBLICA Y MOVIMIENTOS DE TIERRA



Fig. 1



Fig. 2



Fig. 3



Fig. 4



Fig. 5



Fig. 6



Fig. 7



Fig. 8



Fig. 9



Ø	Neumático**	Dibujo	Rueda	Medidas en mm.		Capd. de carga
				ancho	diámetro	
12"	23/8.50-12 TL-6PR	1	7.00-12	231	585	650
15"	27/8.50-15 TL-6PR	1	7K15	231	695	900
	27/10.50-15 TL-8PR	1	9W15	265	695	1150
15.3"	10.0/75-15.3 TL-12PR	2	9.00-15.3	265	760	1600
	11.5/80-15.3 TL-12PR	2	9.00-15.3	287	880	1800
16"	10.5-16-6PR	3	8W16	220	760	1300
	10.50-16 TL-14PR	4	8W16	274	945	2800
16.5"	10-16.5 TL-10PR	1	8.25-16.5	285	788	1800
	12-16.5 TL-12PR	1	8.25-16.5	332	848	2200
18"	10.5/80-18 TL-10PR	9	9W18	288	830	2000
	12.0-18 TL-12PR	2	11W18	289	920	2185
	12.0/75-18 TL-12PR	2	11W18	280	880	2400
19.5"	12.5/80-18 TL-12PR	8	11W18	325	950	2650
	18-19.5 TL-16PR	7 y 9	13.00-19.5	457	1080	5850
20"	9.00-20 TL-14PR	6	8.0V20	256	1012	4000
	10.00-20 TL-16PR	6	9.0V20	280	1050	5000
	10.5-20 TL-10PR	8	9W20	270	955	2100
	12.5-20 TL-12PR	2	11W20	325	1035	2400
	14.5-20 TL-14PR	8	11W20	355	1095	3000

OBRA PÚBLICA Y MOVIMIENTOS DE TIERRA



Fig. 1



Fig. 2



Fig. 3



Fig. 4



Fig. 5



∅	Neumático**	Dibujo	Rueda	Medidas en mm.		Capd. de carga
				ancho	diámetro	
20"	400/70-20 TL-14PR	1 y 3	13W20	400	1076	3670
	405/70-20 TL-14PR (16.0/70-20)	1 y 2	13W20	407	1076	3670
24"	13.00-24-12PR	1	12W24	333	1278	2485
	14.00-24-12PR	1	12W24	362	1348	3010
	15.5/80-24 TL-12PR	2	14W24	404	1250	4160
	405/70-24 TL-14PR (16.0/70-24)	1 y 2	14W24	407	1178	3800
	16.5/85-24 TL-12PR	1	14W24	430	1285	3250
	16.9-24 TL-12PR	1	14W24	430	1285	3100
	17.5-24 TL-18PR (460/70 R 24)	1 y 3	15W24	467	1248	4375
25"	15.5-25 TL-12PR	5	13.00-25	394	1278	5000
	17.5-25 TL-16PR	5	15.00-25	445	1348	6500
	20.5-25 TL-16PR	5	18.00-25	521	1493	8250
	23.5-25 TL-20PR	4	20.00-25	597	1617	9900
26"	18.4-26 TL-12PR	1	15DW26	467	1440	3880
28"	16.5/85-28 TL-12PR	1	14W28	430	1411	3450
	16.9-28 TL-12PR	1	14W28	430	1411	3500
30"	16.9-30 TL-16PR	1	14W30	429	1475	3650

RUEDAS Y NEUMÁTICOS PARA MOTOCULTORES Y PEQUEÑOS TRACTORES



Fig. 1



Fig.2



Fig.3



Fig.4



Ø	Neumático	Dibujo	Diametro mm	Ancho mm	Carga Kg	Rueda
4"	3.00-4	Fig. 1	272	86	130	2.50-4
	4.00-4	Fig. 1	324	105	150	2.50-4
6"	3.50-6	Fig. 1	350	100	205	2.50-6
8"	3.50-8	Fig. 1	395	95	130	2.50-8
	4.00-8	Fig. 1	427	115	260	2.50-8
	16x6.50-8	Fig. 1	420	165	260	5.00-8
10"	18x9.50-8	Fig. 1	480	220	500	7.00-8
	4.00-10	Fig. 1	490	110	185	3.50-10
	5.00-10	Fig. 1	512	140	250	3.50-10
12"	4.00-12	Fig. 1	528	113	250	3.00-12
	5.00-12	Fig. 1	570	133	370	3.00-12
	6.50/80-12	Fig. 1	604	165	500	5J12
	7.00-12	Fig. 3	685	192	580	5J12
	23x8.50-12	Fig. 4	575	214	450	7X12
12"	23x10.50-12	Fig. 4	575	260	600	8.50-12
	26x12.00-12	Fig. 4	650	307	810	10.50-12
	10.0/80-12	Fig. 3	710	238	730	7x12
	11.0/65-12	Fig. 3	692	261	1270	7x12
14"	5.00-14	Fig. 2	636	129	255	
15"	5.00-15	Fig. 1	661	129	430	3.00-15
	6.5/80-15	Fig. 1	680	180	750	5J15
	31x15.50-15	Fig. 4	810	400	1400	13LB15
	7.5L15	Fig. 3	753	209	690	5J15
	8.0/75-15	Fig. 3	708	200	800	7K15
15.3"	10.0/75-15.3 TL	Fig. 3	760	265	1400	9.00-15.3
	10.0/75-15.3	Fig. 3	760	265	1500	9.00-15.3
	11.5/80-15.3 TL	Fig. 3	850	290	1500	9.00-15.3
	11.5/80-15.3	Fig. 3	850	290	1600	9.00-15.3

RUEDAS Y NEUMÁTICOS PARA JARDÍN



Fig. 1



Fig.2



Fig.3



∅	Neumático	Dibujo	Diametro mm	Ancho mm	Carga Kg	Rueda
4"	3.00-4 2PR	Fig. 1	260	86	150	2.50-4
	4.00-4 4PR	Fig. 1	305	102	190	2.50-4
	4.10/3.50-4 4PR	Fig. 2	277	106	150	2.50-4
	11x4.00-4 4PR	Fig. 2	292	106	150	
5"	4.10/3.50-5 4PR	Fig. 2	294	101	160	
	11x4.00-5 4PR	Fig. 2	274	110	150	
6"	285x90 4PR	Fig. 1	285	90	190	2.50-6
	3.50-6 4PR	Fig. 1	330	100	205	2.50-6
	4.10/3.50-6 4PR	Fig. 2	310	90	170	2.50-6
	13x5.00-6 4PR	Fig. 2	330	120	160	4.00-6
	13x5.00-6 6PR	Fig. 3	330	120	250	4.00-6
7"	13x6.50-6 6PR	Fig. 2 y 3	339	169	260	4.00-6
	15x6.00-6 6PR	Fig. 2 y 3	370	160	345	4.00-6
	15x6.00-6 10PR	Fig. 3	370	160	450	4.00-6
8"	3.50-8 4PR	Fig. 1	390	100	200	2.50-8
	4.00-8 4PR	Fig. 1 y 2	410	105	250	2.50-8
	16x6.50-8 6PR	Fig. 2 y 3	414	171	260	5.00-8
	16x6.50-8 10PR	Fig. 3	414	171	490	5.00-8
	16x7.50-8	Fig. 2	426	192	300	5.00-8
	18x8.50-8 TL 6PR	Fig. 2 y 3	450	221	475	7.50-8
	18x9.50-8 TL 6PR	Fig. 2 y 3	470	244	550	7.50-8
	20X10.00-8 TL 4PR	Fig. 2	524	264	550	7.50-8
10"	20x8.00-10 TL 4PR	Fig. 2	509	183	410	6.25-10
	20x10.00-10 TL 4PR	Fig. 2	510	260	550	6.25-10
12"	23x8.50-12 4PR	Fig. 2	575	214	450	7.00-12
	23x10.50-12 TL 4PR	Fig. 2	575	264	610	8.50-12
	24x12.00-12 TL 6PR	Fig. 2	616	293	1000	10.50-12
	26x12.00-12 TL 8PR	Fig. 2	650	307	1020	10.50-12

ÍNDICES DE CARGA Y VELOCIDAD

Indice de carga (IC).

IC	Kg	IC	Kg	IC	Kg	IC	Kg	IC	Kg	IC	Kg
19	77,5	50	190	81	462	112	1120	143	2725	174	6700
20	80	51	195	82	475	113	1150	144	2800	175	6900
21	82,5	52	200	83	487	114	1180	145	2900	176	7100
22	85	53	206	84	500	115	1215	146	3000	177	7300
23	87,5	54	212	85	515	116	1250	147	3075	178	7500
24	90	55	218	86	530	117	1285	148	3150	179	7750
25	92,5	56	224	87	545	118	1320	149	3250	180	8000
26	95	57	230	88	560	119	1360	150	3350	181	8250
27	97,5	58	236	89	580	120	1400	151	3450	182	8500
28	100	59	243	90	600	121	1450	152	3550	183	8750
29	103	60	250	91	615	122	1500	153	3650	184	9000
30	106	61	257	92	630	123	1550	154	3750	185	9250
31	109	62	265	93	650	124	1600	155	3875	186	9500
32	112	63	272	94	670	125	1650	156	4000	187	9750
33	115	64	280	95	690	126	1700	157	4125	188	10000
34	118	65	290	96	710	127	1750	158	4250	189	10300
35	121	66	300	97	730	128	1800	159	4375	190	10600
36	125	67	307	98	750	129	1850	160	4500	191	10900
37	128	68	315	99	775	130	1900	161	4625	192	11200
38	132	69	325	100	800	131	1950	162	4750	193	11500
39	136	70	335	101	825	132	2000	163	4875	194	11800
40	140	71	345	102	850	133	2060	164	5000	195	12150
41	145	72	355	103	875	134	2120	165	5150	196	12500
42	150	73	365	104	900	135	2180	166	5300	197	12850
43	155	74	375	105	925	136	2240	167	5450	198	13200
44	160	75	387	106	950	137	2300	168	5600	199	13600
45	165	76	400	107	975	138	2360	169	5800	200	14000
46	170	77	412	108	1000	139	2430	170	6000	201	14500
47	175	78	425	109	1030	140	2500	171	6150	202	15000
48	180	79	437	110	1060	141	2575	172	6300	203	15500
49	185	80	450	111	1090	142	2650	173	6500	204	16500

Indice de velocidad (IV).

INDICE DE VELOCIDAD (IV)	A1	A2	A3	A4	A5	A6	A7	A8	B	C	D	E	F	G
	5	10	15	20	25	30	35	40	50	60	65	70	80	90
	J	K	L	M	N	P	Q	R	S	T	U	H	V	Z
	100	110	120	130	140	150	160	170	180	190	200	210	240	+ 240

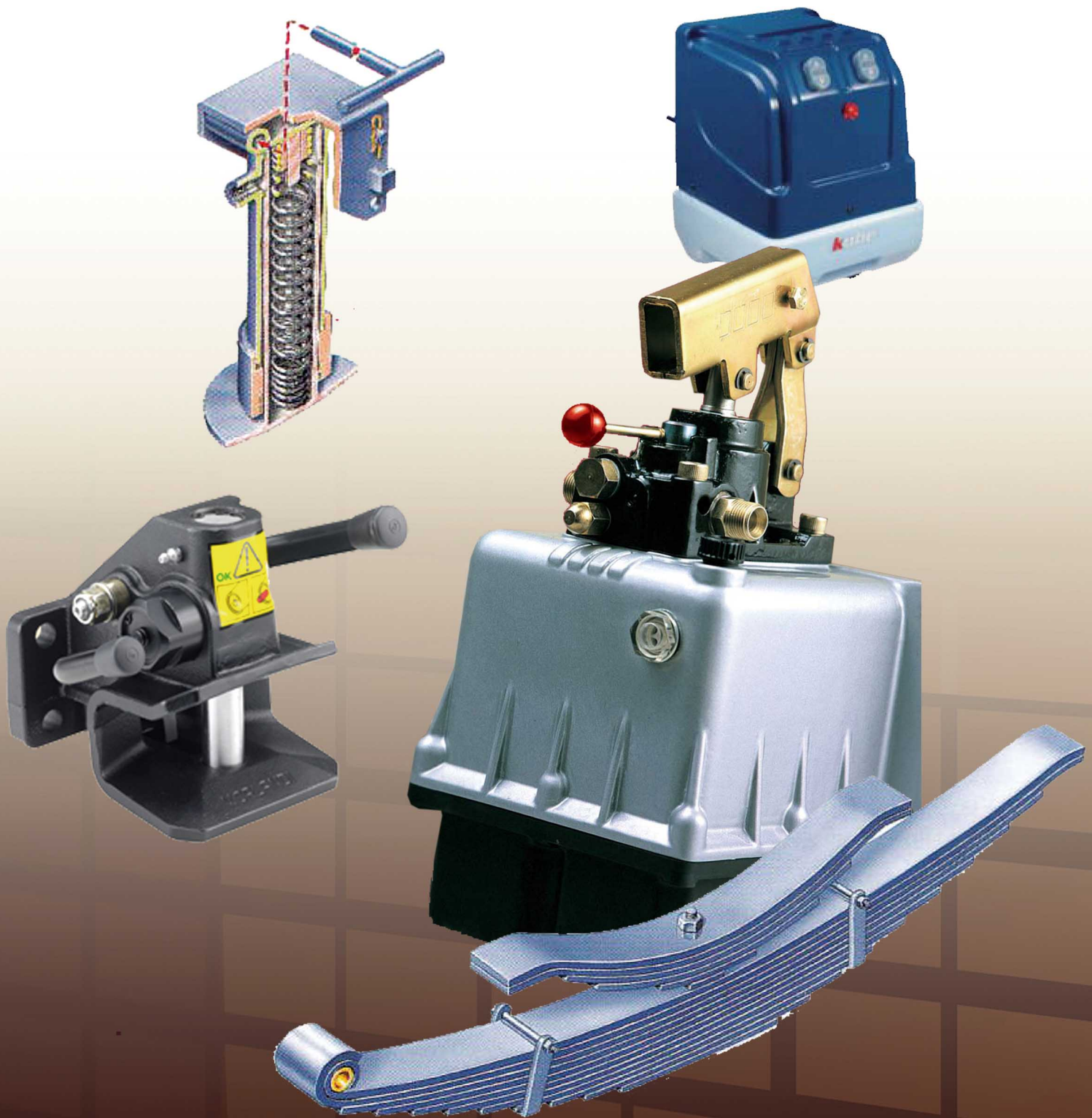

ACCESORIOS Y COMPONENTES VARIOS

PM

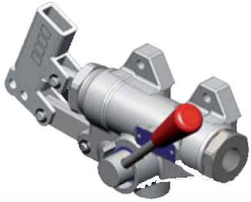

SERIE PM

Bombas manuales sin depósito, caudal 20-50-70 cc con y sin grifo de descarga

PMS



SERIE PMS

Bombas manuales doble efecto, caudal 12-25-45 cc con y sin depósito, para accionamiento cilindros simple efecto. Disponibles con válvula de alivio y regreso automático del grifo de descarga.

PMI

PMS



SERIE PMSI

Bombas manuales doble efecto, caudal 12-25-45 cc con y sin depósito, para accionamiento cilindros doble efecto.



PMI



SERIE PMSE

Bombas manuales de simple efecto, 10-15-16 cm³ con y sin depósito, para el accionamiento de cilindros simple efecto.

PMSI



DEPÓSITOS

Depósitos en aluminio y aluminio/plástico de 1-2-3-5-7-10 litros, completos de nivel de aceite. versiones especiales a petición.

PMSE

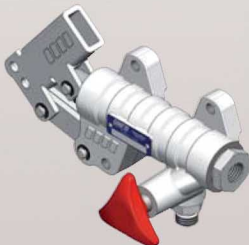

TANKS

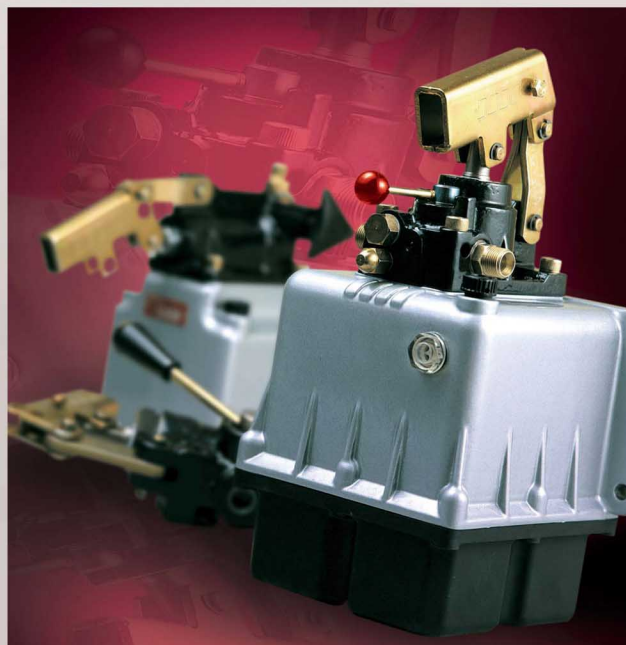
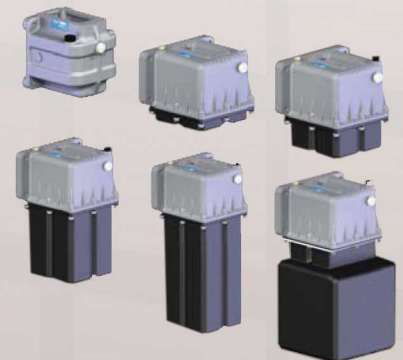

PK-RE/RM



SERIE PK - RE / RM

Minicentrales 12v / 24v dc para volquetes ligeros accionamiento eléctrico y mecánico.

SERIE PK - AC

Minicentrales ac con motores desde 0,5 kw a 3kw, disponibles en diferentes configuraciones.

PK-AC



PK-STD



SERIE PK - STD

Minicentrales 12v / 24v dc con mandos comonibles y bomba manual de emergencia.

POWER-PRO



SERIE POWER-PRO

Nueva centralita 12-24 v dc compacta y versátil para basculantes livianos, con depósito de plástico y concapacidad de 5 ò 9 lt.

KUBE



SERIE KUBE

Centralita electro hidráulica compacta y pre-cableada, ideal para equipos eleva-techo, equipos con gancho y plataformas montacargas.

POWER-PRO WL



SERIE POWER-PRO WL

Centralita pre-cableada para volquetes. Gestión con sistema wireless de mando y diagnosis.

PK-PW



SERIE PK - PW

Motobombas 12v / 24v dc para equipos pequeños.

ACCESORIOS

SERIE ELP - CCV

Motobombas aireadas 12v / 24v dc para equipos grandes.



MPS



SERIE MPS

Motobombas ac con motor desde 1 a 20 kw.

ACCESORIOS

Amplia gama de accesorios.

ELP-CCV



GRUPO MOTOR BOMBA HYDROTIP

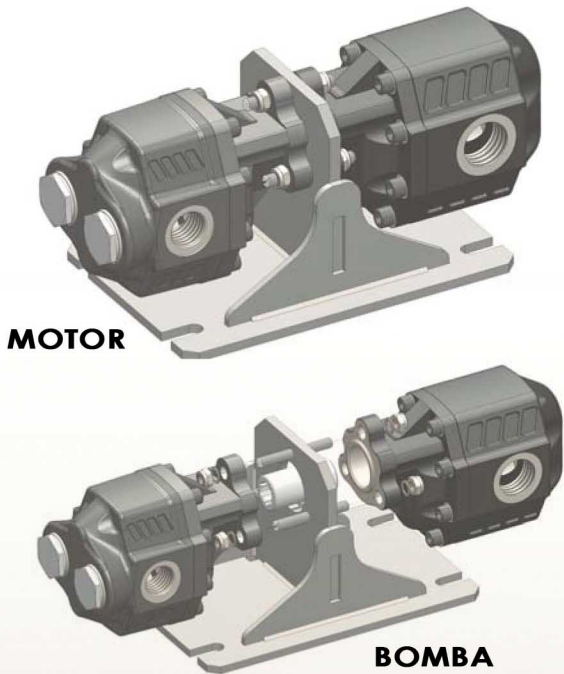

MOTOR

BOMBA

Hydrotip es un dispositivo oleo dinámico que transmite la energía hidráulica del tractor al circuito hidráulico para accionar remolques basculantes.

Está compuesto de un motor acoplado a una bomba, ambas de engranajes, de la probada serie NPH, montadas sobre un soporte de acero que unifica en una pieza y simplifica la instalación sobre la lanza del remolque. Está disponible en 3 configuraciones para conseguir el mejor comportamiento en función de la capacidad o la presión a gusto del cliente.

Gracias a HYDROTIP es posible utilizar el remolque basculante sin utilizar la transmisión a cardan del tractor, con la ventaja que aporta a la maniobrabilidad y a la seguridad sin perder ninguna prestación.

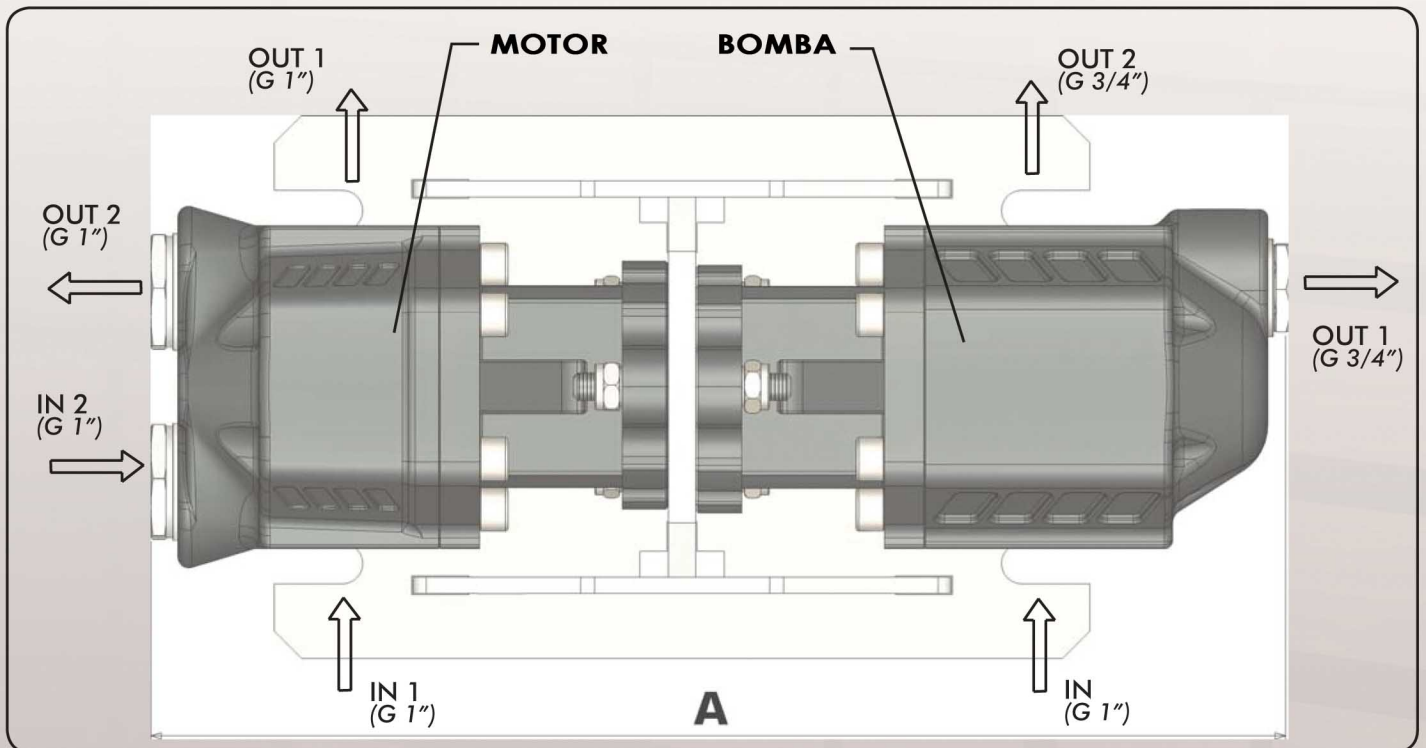

BOMBA	MOTOR	A
NPH 61 SX	MTH 61	390
NPH 73 SX		400
NPH 61 SX	MTH 73	396

GRUPO MOTOR BOMBA HYDROTIP

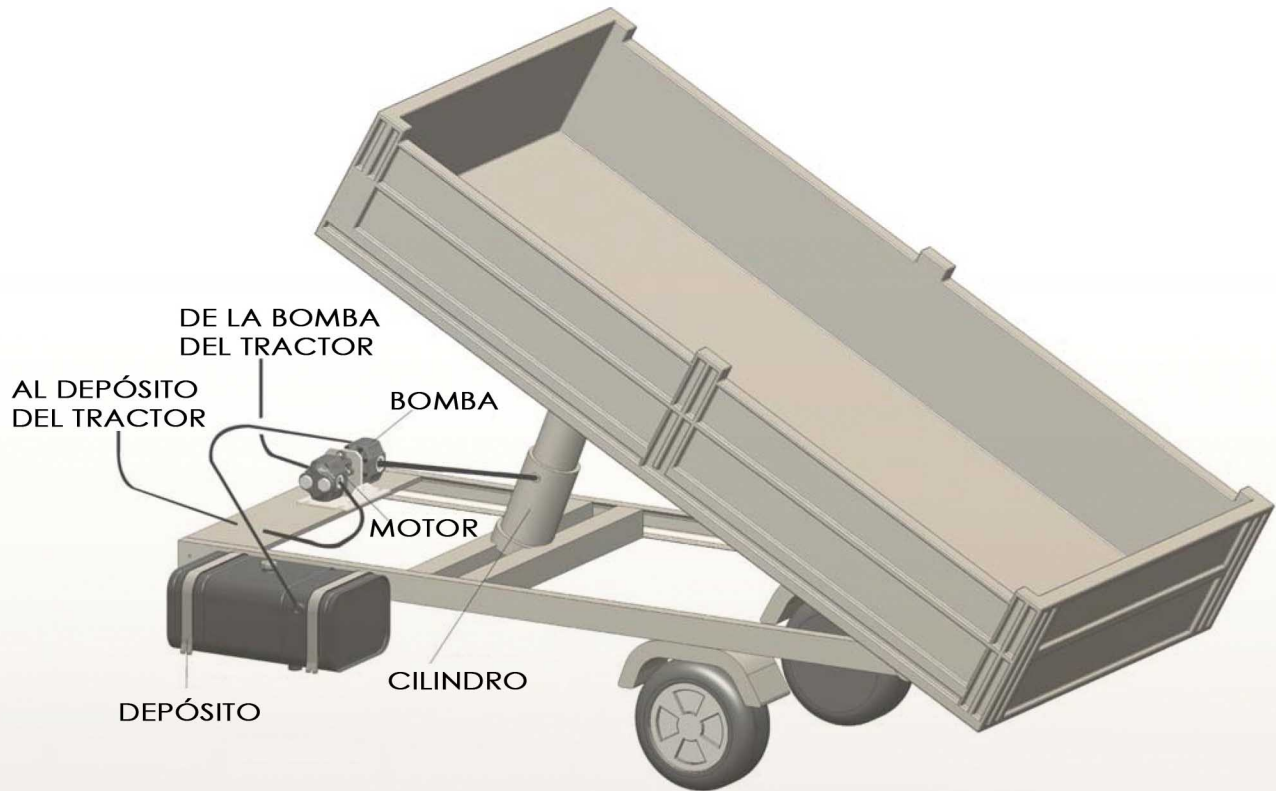

APLICACIONES

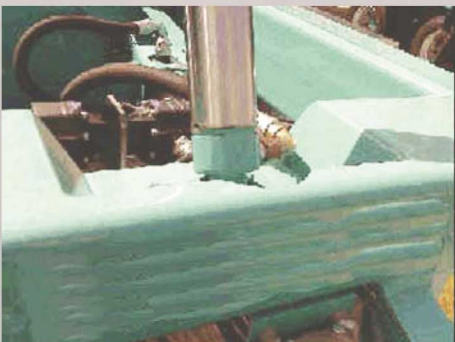

Apoyo hidráulico abatible

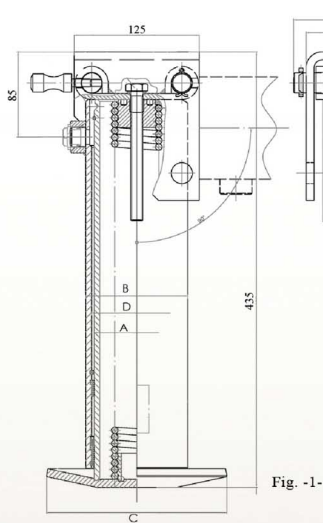

Fig. -1-

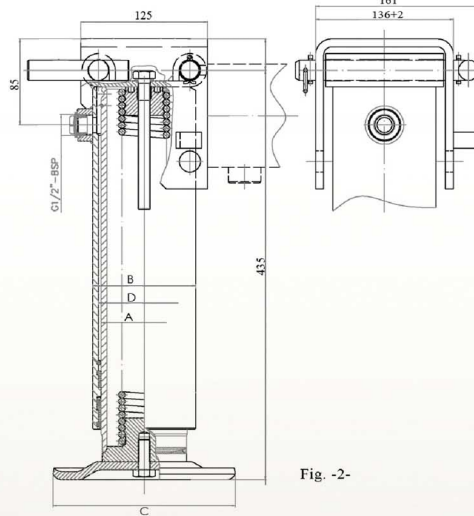
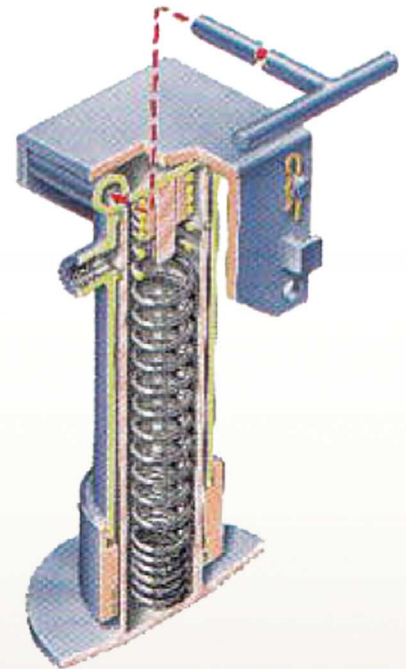

Fig. -2-



Tipo	Dimensiones mm				Carrera mm	Volumen Lt.	Peso Kg.	Capacidad Kg.		Fig.
	A	B	C	D				Bar100	Bar160	
Aph025	65	80	160	70	250	0,8	17	3300	5900	1
Aph026	85	110	220	90	250	1,5	23	5700	10200	1
Aph027	85	110	220	90	250	1,5	23	5700	10200	2

PRESIÓN MAX. DE TRABAJO 160 BAR

Bombas manuales doble embolada sin inversor de flujo

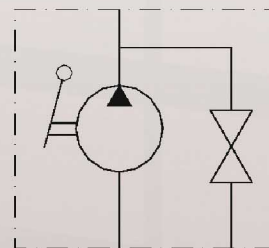
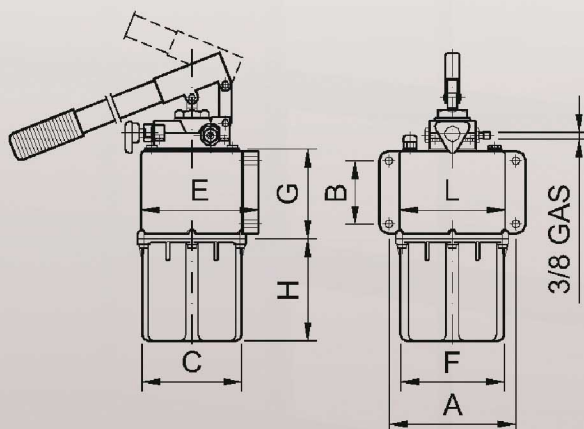

ESQUEMA HIDRAULICO SIN INVERSOR DE FLUJO



Cód.	Referencia	Caudal c.c.	Capac. depósito	Presión BAR max.	A	B	C	E	F	G	H	L	Peso Aprox. (Kg.)
Bhm001	Bomba manual PMS 25 2L s/p	25	2	300	180	90	147	166	147	125	25	150	4,8
Bhm002	Bomba manual PMS 25 3L s/p		3								65		5,2
Bhm003	Bomba manual PMS 25 5L s/p		5								175		5,2

APOYO ESTABILIZADOR DOBLE EFECTO

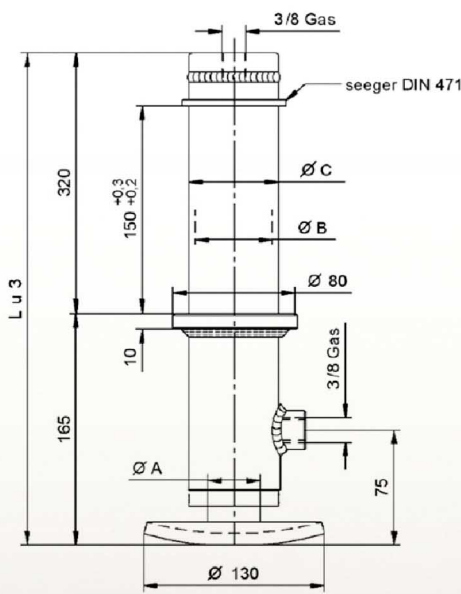

PIE-9010

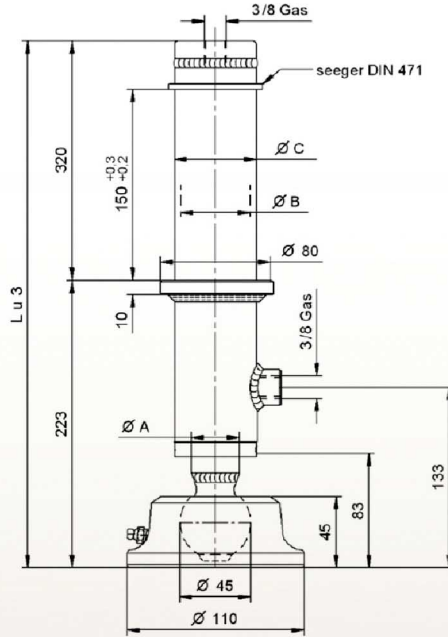

PIE-9012

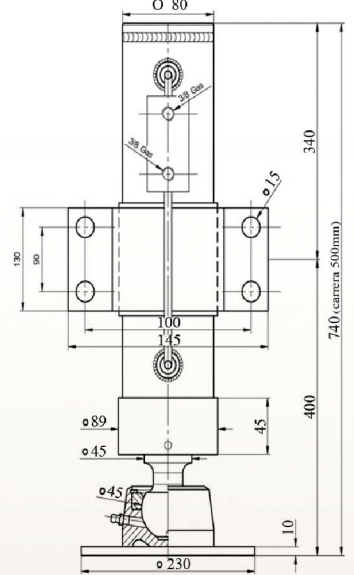

PIE-9008

TIPO	DIMENSIONES mm				CARRERA mm	CAPACIDAD Kg.
	ØA	ØB	ØC	L		
PIE-9010	35	50	60	485	325	3500
PIE-9012	35	50	60	543	325	3500
PIE-9008	45	60	80	740	500	9000

Cuerpo cromado

PIE DE APOYO HIDRÁULICO DOBLE EFECTO CON VÁLVULA DE BLOQUEO



Cod.	Vástago	Carrera mm	A mm	F mm	C mm	Smm	D mm	Capacidad a 150 Bar
APY050	40	400	80	600	65	4	220	1700
APY051	40	500	80	700	65	4	220	1700
APY052	50	400	90	600	65	4	220	2650
APY053	50	500	90	700	65	4	220	2650
-	50	600	90	800	65	4	220	2650
APY054	60	400	100	600	65	4	280	3800
APY055	60	500	100	700	65	4	280	3800
APY056	60	600	100	800	65	4	280	3800
APY057	70	500	110	700	65	4	280	5200

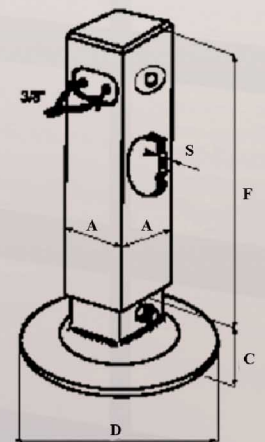

APOYOS CON RUEDA

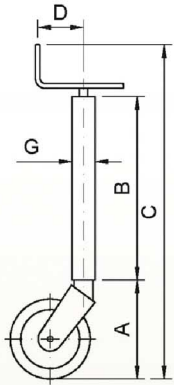

Fig. - 1 -

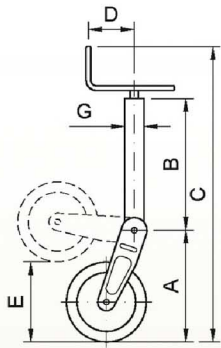

Fig. - 2 -

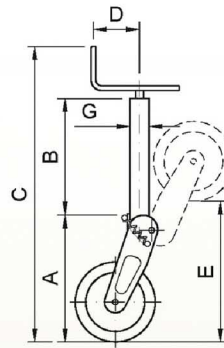
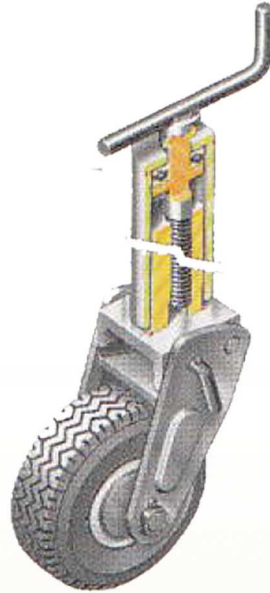

Fig. - 3 -

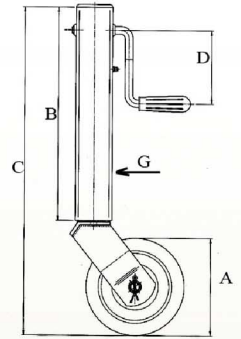

Fig. - 4 -

APOYOS CON RUEDA FIJOS O ABATIBLES

Cód.	Referencia	Fig.	Carga vertical (Kg.)	Carrera	A	B	C	D	E	G		Rueda	Peso Aprox. (Kg.)
										φ	□		
Apy081B	APY M/SUP R60-RDAM-220x60 IMPR	1	800	210	275	380	795	115	-	60	-	220x60	9
Apy081	APY M/SUP R60-RDAM-220x60 ZINC												
Apy023	APY ABT. M/SUP C60-RDAM-220x60 MLL	3	800	220	310	840	840	-	280	-	60	220x60	10
Apy029	APY ABT. M/SUP C60-RDAM-220x60 PAS	2											9,7
Apy031	APY APT. M/SUP C70-RDAM-275x70 PAS	2	1000	300	370	460	985	185	290	-	70	275x70	13,5
Apy090	APY.CRDA. C60x300 RDMA-200x65 Atomizador	4	600	150	160	350	540	120	-	-	60	160x60	8

ELEVADOR PARA LANZA



Código	□	Carrera	Peso	B	C	E
Apy704	70	400	20,0	660	400	165

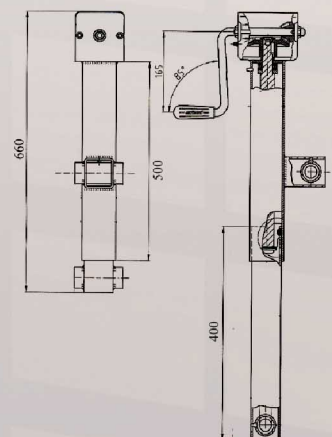

APOYO SIN RUEDA

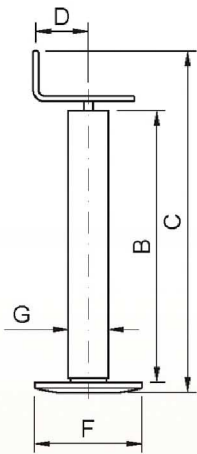

Fig. - 1 -

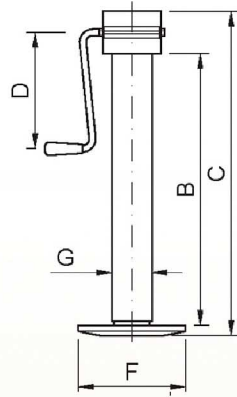

Fig. - 2 -

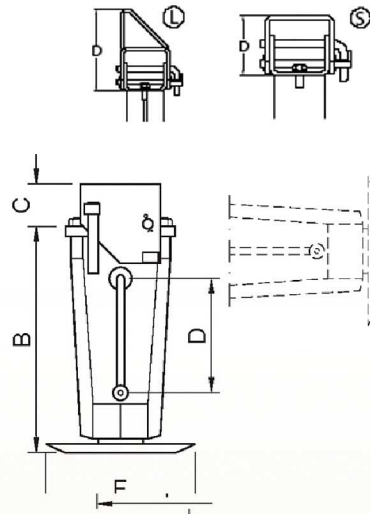
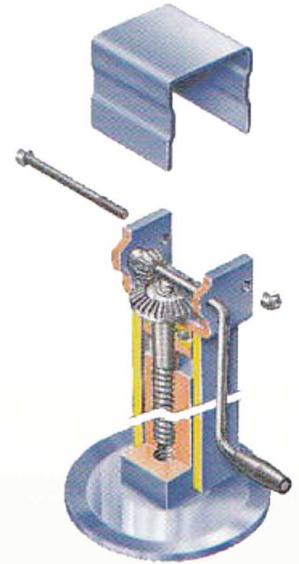

Fig. - 3 -



APOYOS SIN RUEDA FIJOS Y ABATIBLES

Cód.	Referencia	Fig.	Carga vertical (Kg.)	Carrera	B	C	D	F	G	Peso Aprox. (Kg.)
Apy003	APY.C.50-300 CARR	1	300	300	460	590	115	160	50	5,3
Apy006	APY.C.60-300 CARR		600						60	6
Apy009	APY.C.70-300 CARR		1000		70	9,3				
Apy012	APY.C.80-300 CARR		1200		80	13				
Apy016	APY M/LAT RED 2/1 C70-310 CARR	2	3000	310	500	620	220	225	70	14,5
Apy019	APY M/LAT RED 2/1 C80-310 CARR		4000						80	15,6
Apy048	APY C70-170 CAR ABT DS510 S	3 S	6000	170	330	115			-	15,5
Apy047	APY C70-170 CAR ABT DS510 L	3 L	6000	170	330	225	235	220	-	17,5

ELEVADOR PARA REMOLQUES TANDEM 3 EXPANSIONES



Código	□	Carrera	Figura	Peso	Carga	B	C	E	G	H
K450	110	280	1	32,0	4500	675	280	325	250	300
KRA 750	110	380	2	42,5	10000	775	380	250	250	300
KRA 750 FLN	110	380	2	42,5	10000	775	380	250	250	300

APOYOS Y RUEDAS JOCKEY ABATIBLES

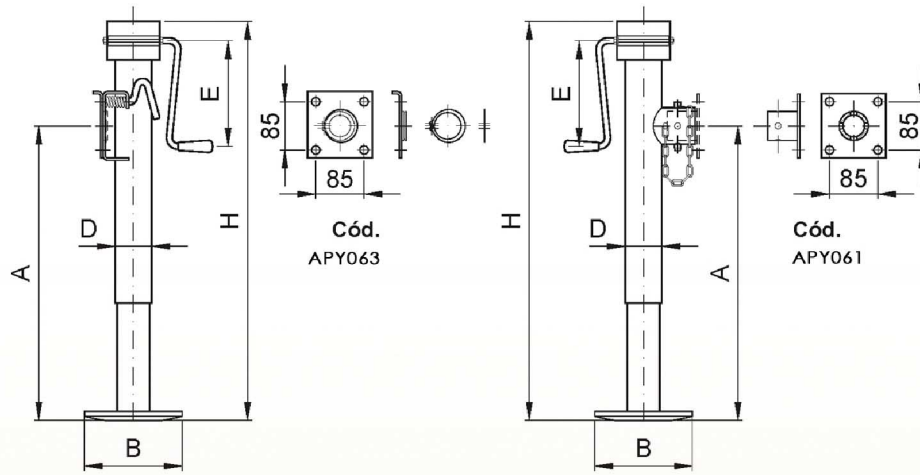
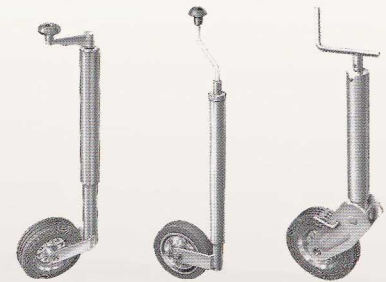

Fig. -1-

Fig. -2-

Cód.	Referencia	Fig.	Kg	Carrera	A (MÍN)	B	D	E	H	Peso Aprox. (Kg.)
APY062	APY.TLC. 57-LF/AB-ML	1	1300	380	405	160	057	168	560	7,3
APY060	APY.TLC. 57-LT/AB-ML	2								7,1



APOYOS FIJOS Y RUEDAS JOCKEY ESTÁNDAR

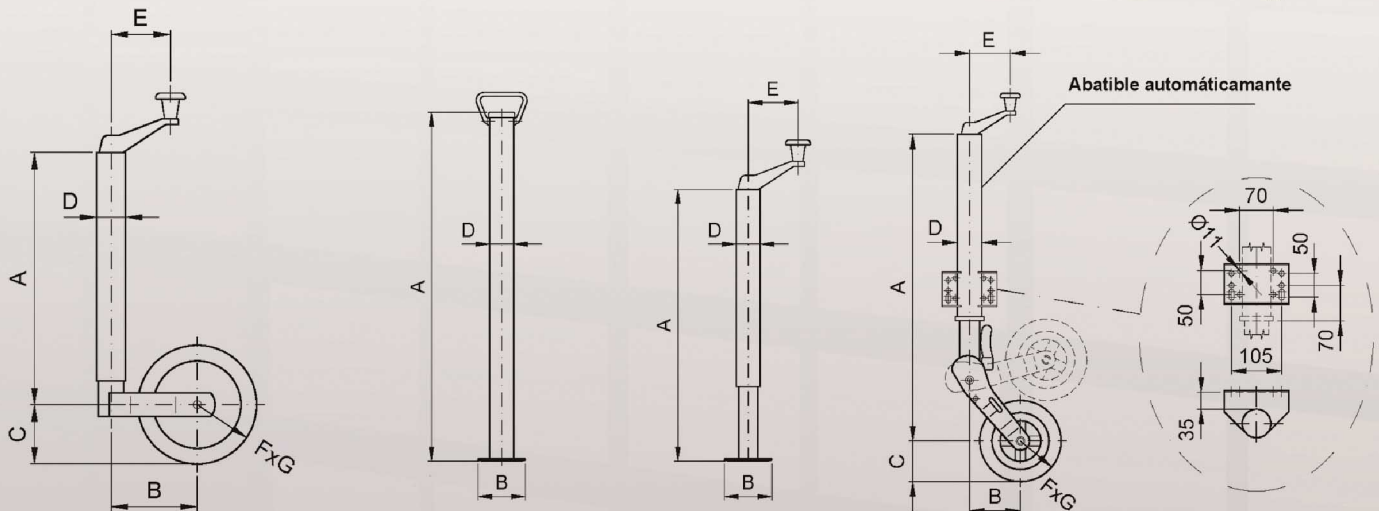

Fig. -1-

Fig. -2-

Fig. -3-

Fig. -4-

Cód.	Referencia	Fig.	Kg	Carrera	A (MÍN)	B	C	D	E	FxG	Peso Aprox. (Kg.)
APY041	RDAJCKY M/SUP R48-RDA G 200x50	1	150	220	420	145	120	∅48	100	200x50	5,0
APY043	RDAJCKY M/SUP R60-RDA G 220x70	1	400	250	430	170	150	∅60	185	220x70	10,8
APY091	APY.FIJO T-48x700	2			700	95		∅48			2,0
APY092	APY.FIJO T-48x400/620	3	300	220	400	95		∅48	100		3,0
APY073	RDAJCKY ABT.AUT. R60-200x60	4	300	250	700	125	100	∅60	100	200x60	9,0

BRIDAS PARA APOYOS Y RUEDAS JOCKEY

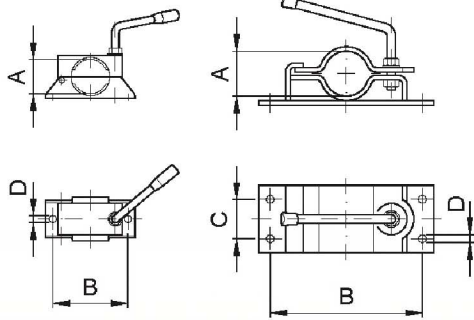
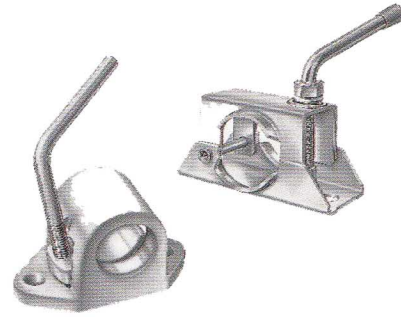

Fig. - 1 -

Fig. - 2 -



Cód.	Referencia	Fig.	A	B	C	D	Nº de agujeros	Peso Aprox. (Kg.)
Apy072	BR - 48 - ST		φ 48	105			2	
Apy082	BR - 60 - ST	2	φ 60		50		4	3,4
Apy082B	BR - 60 - SPL			213	55	φ 11		

PATAS EXTENSIBLES

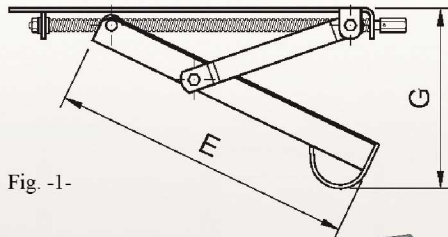

Fig. -1-

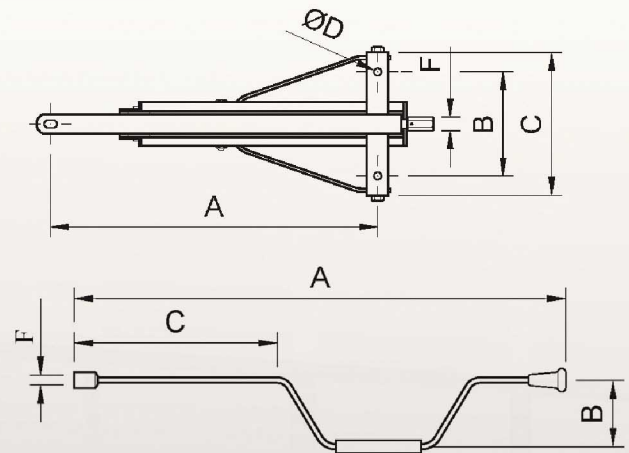
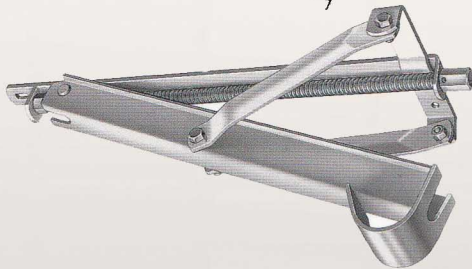

Fig. -2-

Cód.	Referencia	Fig.	Carga (*) admisible (Kg.)	A	B	C	Ø D	E	F (Entre caras)	G máx.	Peso Aprox. (Kg.)
Apy083	Estabilizador extensible SC480	1	300	480	135	195	9	480	19	470	3,4
Apy084	Manivela MS650	2	-	665	100	345	-	-	19	-	0,8

ANTIRROBO UNIVERSAL PARA ENGANCHE CINCO CON CANDADO



Acc453



Acc454

BALLESTAS MULTIHOJA

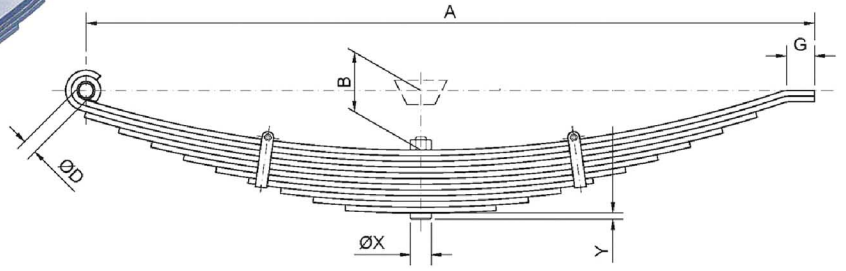
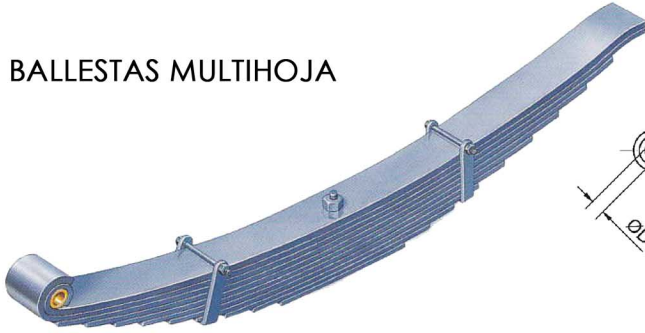

Cód.	Referencia	Perfil	Nº de hojas	A	B	φ D	G	φ X	Y	Carga estática (Kg)	Peso Aprox. (Kg.)
Bal024	B-50 x 8 / 7 A 800 OR	50 x 8	7	800		23	70	15		1150	13
Bal026	B-100 x12/10 A1064 OR	100x12	10		130	30	100	16	10	5000	72
Bal027	B-100 x12/12 A1064 OR	100x12	12							6000	85

BALLESTAS CON BALLESTÍN

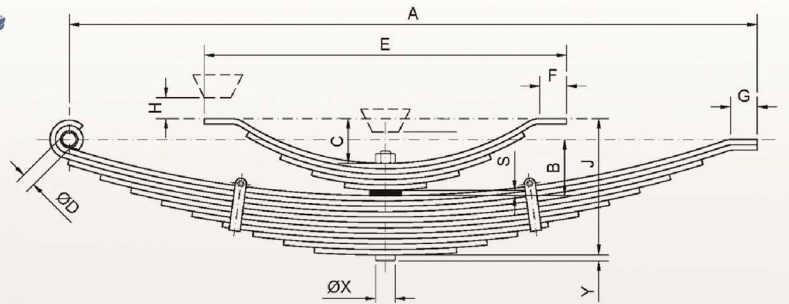

Cód.	Referencia	Perfil	Nº de hojas	A	B	C	φ D	E	F	G	J	φ X	Y	Carga estática (Kg)	Peso Aprox. (Kg.)	
Bal028	B-57x8/8 + 4 A 800 OR	57 x 8	8	4	800						204			2600	25	
Bal020	B-57x8/10 + 5 A 900 OR		10	5	900	130	100	23				228	15		3100	31
Bal029	B-57x8/12 + 6 A 900 OR		12	6					600	60	70	252		10	3700	39
Bal021	B-70x10/10 + 5 A 1000 OR	70x10	10	5	1000	105	75	25			234			6000	50	
Bal022	B-70x10/12 + 6 A 1000 OR		12	6								265	17		7100	57

BALLESTAS PARABOLICAS

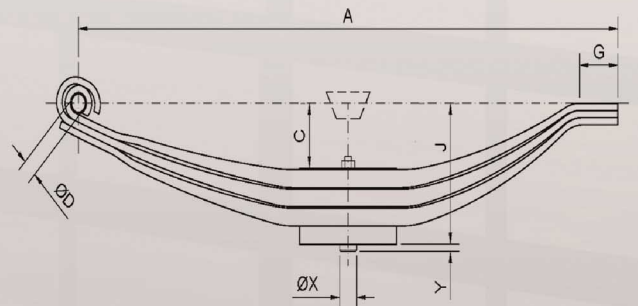
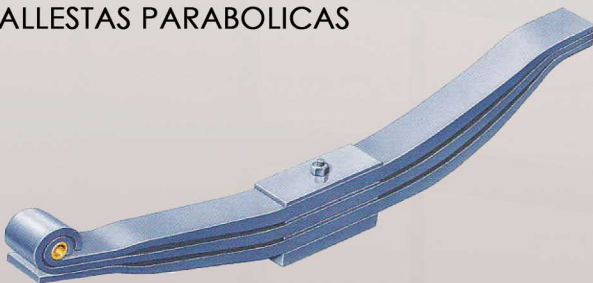

Cód.	Referencia	Perfil	Nº de hojas	A	C	φ D	G	J	φ X	Y	Carga estática (Kg)	Peso Aprox. (Kg.)
Bal006	BP-70x25/1 A 1000 OR	70x25	1					194			1750	20
Bal007	BP-70x25/2 A 1000 OR		2	1000	90	25	100	196	15	10	2800	27,5
Bal008	BP-70x25/1 A 1000 OR		3					196			4200	35,4
Bal009	BP-70x25/1 A 1000 OR		4					198			5600	44,2

ACCESORIOS PARA BALLESTAS

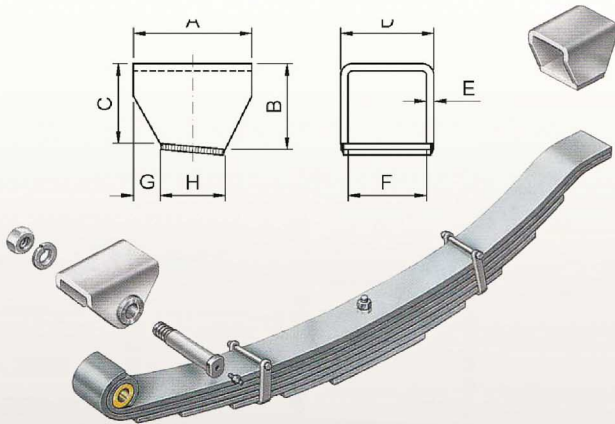
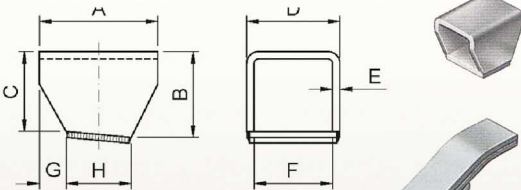
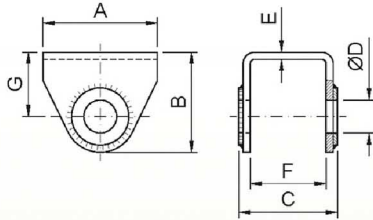
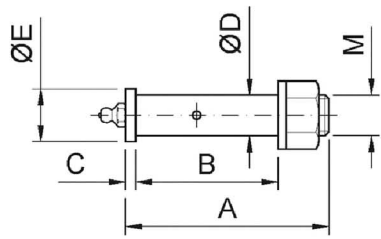

BULONES PARA OJO DE BALLESTA CON TUERCA

Cód.	Referencia	A	B	φD	E	M	Peso Aprox. (Kg.)
Acc464	22,50 x 70 x Ball. H50	100	70	22,5	26	M- 20 x1,5	0,2
Acc317	22,50 x 85 x Ball. H60	120	85	22,5	26		0,36
Acc318	24,50 x 105 x Ball. H70	141	105	24,5	28		0,5
Acc462	30 x 130 x Ball. H100	176	130	30	40	M- 27	0,7

SOPORTES PARA OJO DE BALLESTA

Cód.	Referencia	A	B	C	φD	E	F	G	Peso Aprox. (Kg.)
Acc465	SB03 x Ball.H50	80	70	69	23	5	53	45	0,4
Acc415	SB02 x Ball. H60	90	75	84	23	8	62	50	0,8
Acc340	SB01 x Ball. H70	100	88	103	25,5	10	75	62	1,4
Acc466	SB04 x Ball.H100	110	85	133	30	14	105	55	1,6

SOPORTES PARA RESBALÓN DE BALLESTA

Cód.	Referencia	A	B	C	D	E	F	H	Peso Aprox. (Kg.)
Acc467	SB03xBall H50	80	58	54	63	5	53	44	0,4
Acc420	SB02xBall H60	90	63	59	80	8	64	50	1
Acc347	SB01 xBall H70	100	65	60	97	10	77	56	1,6
Acc468	SB04xBall H100	115	120	120	120	8	104	90	2

BALLESTAS DE LANZA Y ACCESORIOS

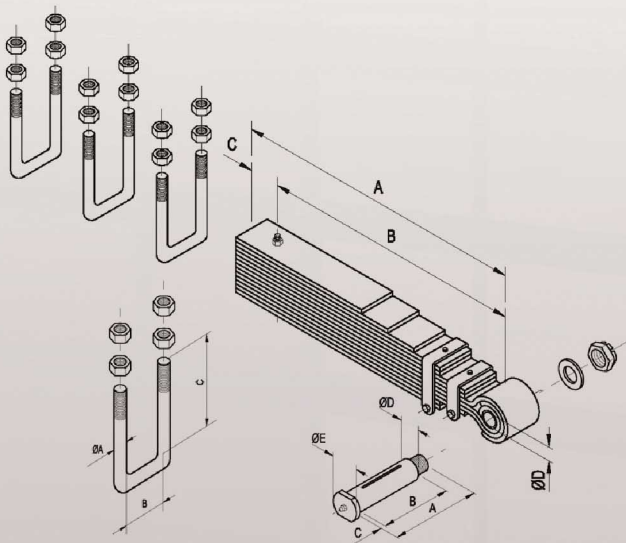

BALLESTAS DE LANZA



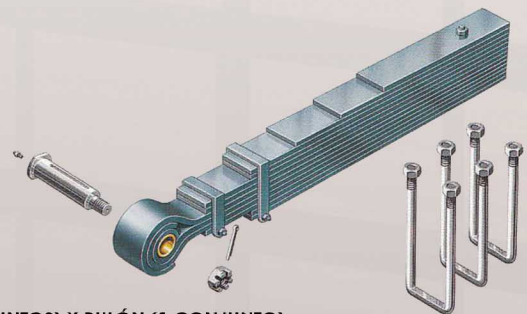



Cód.	Referencia	Carga Vertical (Kg.)	Dimensiones en mm.				Ballesta		Peso Aprox. (Kg.)
			A	B	C	D	Nº de hojas	Sección (mm.)	
Bal003	B-120x14/9 A970	2500	970	870	100	45	9	120x14	105
Bal004	B-120x14/11 A970	2900					11		130
Bal005	B-120x14/13 A970	3300					13		150
Bal002	B-100x45 2H A795	5000	795	575	220	30	2	100x45	53









ABARCONES (3 CONJUNTOS) Y BULÓN (1 CONJUNTO)

Cód.	Referencia	Dimensiones en mm.					Rosca	Peso Aprox. (Kg.)
		A	B	C	φD	E		
Bal010	Bulón 44,5x160 c/tea.	200	160	10	44,5	60	M33x2	2
Bal030	Abarcón M-30x121x230 c/cas.	30	121	230			M-30x2	4,5
Bal031	Abarcón M-30x121x260 c/cas.			260				5







ENGANCHE PASADOR					
serie	homologación	descripción	para anillos		
E 40 	94/20/CE	ENGANCHE AUTOMÁTICO RÍGIDO	Ø 40 mm	✓	✓
EH 45 	94/20/CE	ENGANCHE AUTOMÁTICO CAMPANA ARTICULADA	Ø 45 mm	✓	
NUOVO LUPO 	CUNA NC 138 - 55	ENGANCHE MANUAL CAMPANA ARTICULADA	Ø 45 mm	✓	
E 50 	94/20/CE	ENGANCHE AUTOMÁTICO RÍGIDO	Ø 50 mm	✓	✓
EH 50 	94/20/CE	ENGANCHE AUTOMÁTICO CAMPANA ARTICULADA	Ø 50 mm	✓	
MCX 50 	94/20/CE	ENGANCHE AUTOMÁTICO MODULAR	Ø 50 mm	✓	
MV 50 	94/20/CE	ENGANCHE AUTOMÁTICO S/NORMA BNA	Ø 68 T	✓	✓
GX 57 	94/20/CE	ENGANCHE AUTOMÁTICO RÍGIDO	Ø 57,5 mm	✓	✓
GA 25 	94/20/CE	ENGANCHE AUTOMÁTICO VEHÍCULOS LIGEROS	Ø 40 mm Ø 35 T Ø 45 T swiss	✓	✓
GA 38 	94/20/CE	ENGANCHE AUTOMÁTICO VEHÍCULOS LIGEROS	Ø 40 mm	✓	✓
ENGANCHES ESPECIALES					
GS 900 	94/20/CE	ENGANCHE TRANSPORTE VEHÍCULOS			✓
NEW TITANO 	CUNA NC 138 - 40	ENGANCHE PARA REMOLQUES EXCEPCIONALES	Ø 50 mm	✓	
GM 10 		ENGANCHE DE MANIOBRA	Ø 50 mm Ø 40 mm Ø 76 T	✓	

ENGANCHE A BOLA					
serie	homologación	descripción	para anillos		
DE710-711 	94/20/CE	ENGANCHE A BOLA ISO 50 VEHÍCULOS LIGEROS	B 50 Ø 76 T	✓	✓
DE702-DE704 	94/20/CE	ENGANCHE A BOLA ISO 50 VEHÍCULOS LIGEROS	B 50 Ø 50 mm Ø 40 mm Ø 76 T	✓	✓
DE713 	94/20/CE	ENGANCHE A BOLA ISO 50 VEHÍCULOS LIGEROS	B 50	✓	✓
DEDALO 	94/20/CE	ENGANCHE A BOLA ISO 50 VEHÍCULOS LIGEROS	B 50	✓	✓

ENGANCHE DE GANCHO					
UN 76 	ECE R 55	ENGANCHE DE GANCHO	Ø 76 T	✓	✓
UN 45 	94/20/CE	ENGANCHE DE GANCHO PARA VEHÍCULOS LIGEROS	Ø 45 T Ø 76 T	✓	✓
ULPYO 	CUNA NC 138 - 40	ENGANCHE DE GANCHO PARA VEHÍCULOS LIGEROS	Ø 45 T Ø 76 T	✓	✓

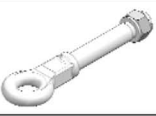
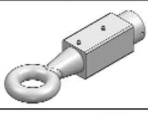

KIT APERTURA MECÁNICA		
DESCRIPCIÓN	PARA ENGANCHES SERIE	
	APERTURA MECÁNICA A DISTANCIA	GA250 - GA252 E50 - EH50 - EHHI - MCX50
KIT APERTURA NEUMÁTICA		
	APERTURA NEUMÁTICA	E 50 - EH 50 - EH 45 MCX 50
KIT INDICADORES CABINA		
	INDICADOR ABIERTO/CERRADO + LÍMITE DE DIRECCIÓN	E 50 - E 40 - EH 50 EH 45 - MCX 50

Ø 40 mm				
	serie	descripción		
	OC40W	ANILLO SOLDABLE	✓	
	OC40R	ANILLO DESMONTABLE	✓	✓
	OC40F	ANILLO EMBRIDABLE	✓	✓
Ø 45 mm				
	OC45R	ANILLO DESMONTABLE	✓	
Ø 50 mm				
	OC50W	ANILLO SOLDABLE	✓	
	OC50R	ANILLO DESMONTABLE	✓	
	OC50F	ANILLO EMBRIDABLE	✓	✓
	OC50FSE	ANILLOS ESPECIALES	✓	✓
Ø 57,5 mm				
	OC57W	ANILLO SOLDABLE	✓	✓
	OC57F	ANILLO EMBRIDABLE	✓	✓

Ø 45 mm - Ø 68 mm - Ø 76 mm TÓRICAS				
	serie	descripción		
	OC45T	ANILLO DESMONTABLE	✓	
	OC68R	ANILLO DESMONTABLE BNA	✓	✓
	OC68F	ANILLO EMBRIDABLE BNA	✓	✓
	OC76W	ANILLO SOLDABLE	✓	
	OC76T	ANILLO SOLDABLE	✓	
	OC76T-R	ANILLO DESMONTABLE	✓	
	OC76B	BARRA DE REMOLQUE	✓	

TRAVESAÑOS

serie	homologación	descripción		
S 2000 	94/20/CE	IVECO Daily City Camion	✓	✓
TE 3000 	94/20/CE	IVECO Eurocargo	✓	✓
CANTER 	94/20/CE	MITSUBISHI Canter	✓	✓
WPTR 	94/20/CE	Travesaño para motriz con enganche rebajado	✓	✓
WPTP 	70/121/CE 2006/20/CE	Parachoques posterior abatible		

	homologación	descripción	
	94 / 20 / CE	ARTICULACIÓN BULÓN O GOMA DE APOYO ISO	2"
	94 / 20 / CE	ARTICULACIÓN BULÓN - APOYO ISO SOLDABLE	2"
	ECE - R55 94 / 20 / CE	ARTICULACIÓN BULÓN - APOYO ISO	2"
	ECE - R55 94 / 20 / CE	ARTICULACIÓN BULÓN O GOMA DE APOYO ISO	3,5"

KINGPIN

	homologación	descripción	
	90 / 20 / CE	KINGPIN	2" y 3,5"

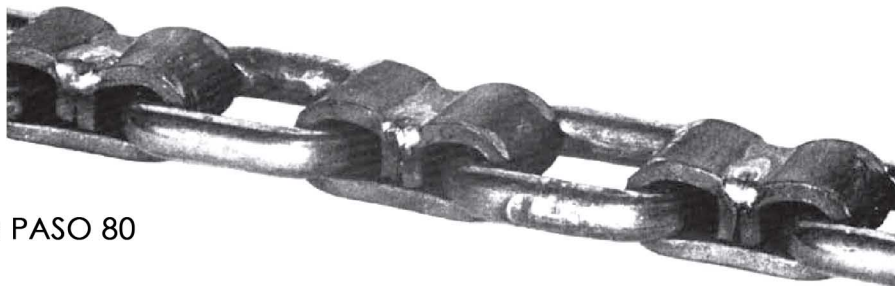

CADENA: PASO 80

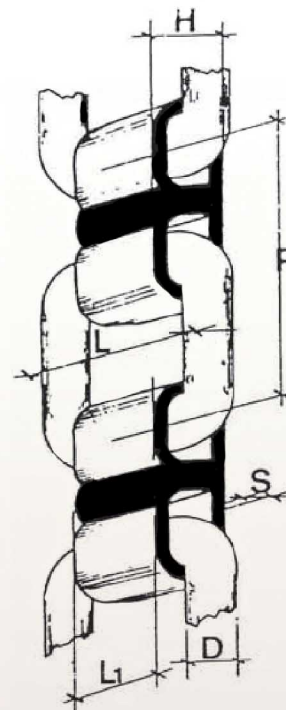

Cod.	ACC497	ACC460	ACC498	ACC499
Tipo	80/9	80/12	80/12X	80/13X
P= Paso	80		81,75	
D = Ø anillo	9		12	
L= Ancho cadena	45		56	
L1= Ancho lazo	25		30	
S= Espesor lazo	4		5	
H= Altura lazo	19		24	
CR= Carga de ruptura (kg)	3.500	6.500	9.000	13.000
Material anillo	CK10		20Mn 5	19MnB 4 Trat. Térmico
Material lazo	Laminado St. 44.2		Laminado St.52.3	
Peso x metro	2,3		4	

CADENA: OTROS PASOS Y MEDIDAS*

Paso 73, 90 y 100 Cargas de ruptura desde 1.500 kg. hasta 13.000 kg.



Paso 80 y 100 Carga de ruptura 15.000 kg. Material laminado y domex



* Consultar plazo de entrega y disponibilidad

JUNTAS PARA CADENAS

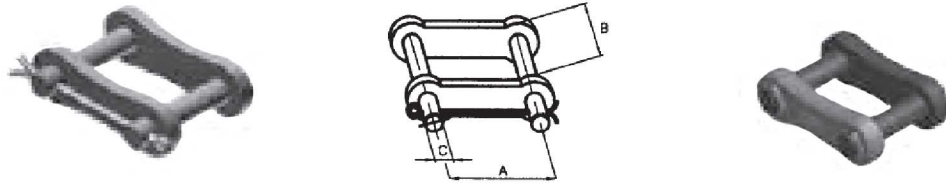

COD	REF.	A	B	C	Peso kg.
ACC500	Junta cad. 80/9	44	21	6,5	0,15
ACC461	Junta cad. 80/12/S/X	47	24	8	0,2
ACC501	Junta cad. 80/13/X	30	30	14	0,2

PIÑONES



COD	REF.	Paso P	Dientes Z	DP	S	D	MAT.	Peso kg.
ACC502	Piñon 80/5 Ø 35	81,75	5	130	23	35	Acero Fe430B	1,8
ACC503	Piñon 80/5 Ø 40					40		
ACC504	Piñon 80/5 Ø 45					45		

RODILLO TENSOR

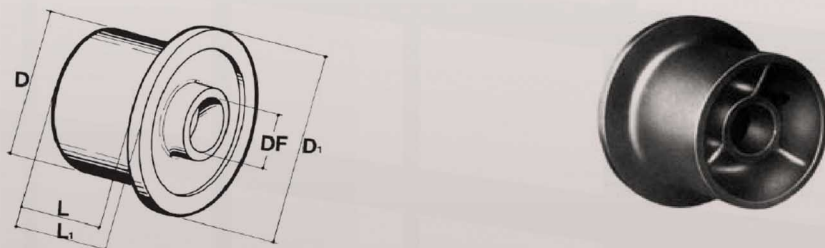

COD	REF.	D	DF	D1	L	L1	MAT.	Peso kg.
ACC505	Rod. Tensor R-1	105	35,5	145	82	100	FUND. G25	3



LA LEONESSA

AGRI
STEFEN

FAD ASSALI



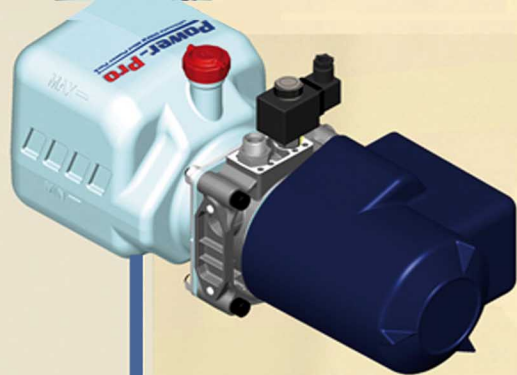

DMFB
HYDRAULIC COMPONENTS®



DINATALE
BERTELLI SPA



V. ORLANDI

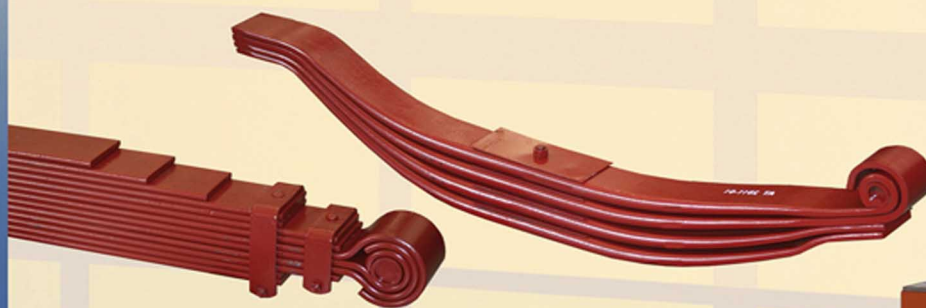

simol

CATÁLOGO GENERAL

07/13





ARTITRAIL

Polígono Centrovía

C/ Bogotá 11-13

50.198 Centrovía-La Muela

Zaragoza

Tel: +34 976 144 749 Fax: +34 976 149 196

www.artitrail.com - artitrail@artitrail.com

